

SERVICE MANUAL

FOR MODEL

HK-160

1	1-1	(1)
2	1-2	(1)
3	2-1	(2)
4	2-2	(2)
5	2-3	(2)
6	2-4	(2)
7	2-5	(2)
8	2-6	(2)
9	2-7	(2)
10	2-8	(2)
11	2-9	(2)
12	2-10	(2)
13	2-11	(2)
14	2-12	(2)
15	2-13	(2)
16	2-14	(2)
17	2-15	(2)
18	2-16	(2)
19	2-17	(2)
20	2-18	(2)
21	2-19	(2)
22	2-20	(2)
23	2-21	(2)
24	2-22	(2)
25	2-23	(2)
26	2-24	(2)
27	2-25	(2)
28	2-26	(2)
29	2-27	(2)
30	2-28	(2)
31	2-29	(2)
32	2-30	(2)
33	2-31	(2)
34	2-32	(2)
35	2-33	(2)
36	2-34	(2)
37	2-35	(2)
38	2-36	(2)
39	2-37	(2)
40	2-38	(2)
41	2-39	(2)
42	2-40	(2)
43	2-41	(2)
44	2-42	(2)
45	2-43	(2)
46	2-44	(2)
47	2-45	(2)
48	2-46	(2)
49	2-47	(2)
50	2-48	(2)
51	2-49	(2)
52	2-50	(2)
53	2-51	(2)
54	2-52	(2)
55	2-53	(2)
56	2-54	(2)
57	2-55	(2)
58	2-56	(2)
59	2-57	(2)
60	2-58	(2)
61	2-59	(2)
62	2-60	(2)
63	2-61	(2)
64	2-62	(2)
65	2-63	(2)
66	2-64	(2)
67	2-65	(2)
68	2-66	(2)
69	2-67	(2)
70	2-68	(2)
71	2-69	(2)
72	2-70	(2)
73	2-71	(2)
74	2-72	(2)
75	2-73	(2)
76	2-74	(2)
77	2-75	(2)
78	2-76	(2)
79	2-77	(2)
80	2-78	(2)
81	2-79	(2)
82	2-80	(2)
83	2-81	(2)
84	2-82	(2)
85	2-83	(2)
86	2-84	(2)
87	2-85	(2)
88	2-86	(2)
89	2-87	(2)
90	2-88	(2)
91	2-89	(2)
92	2-90	(2)
93	2-91	(2)
94	2-92	(2)
95	2-93	(2)
96	2-94	(2)
97	2-95	(2)
98	2-96	(2)
99	2-97	(2)
100	2-98	(2)

NOTICE

This manual is revised version of the Service Manual for Model MK-70 knitter for the use on the Model HK-160 knitter.

The section of the Tension Pole must be ignored as it is changed into the normal Yarn Rod with Auto-Tension.

CONTENTS

[1] OUTLINE OF MODEL HK-160	1
1-1 Main specifications for the machine	1
1-2 Lubricant and cleaning solvent	1
[2] CAUTION	
[3] DISASSEMBLY OF NEEDLEBED	
3-1 Disassembly of the needlebed A	3
3-2 Removal of the front rail, rear rail and plate spring	7
3-3 Removal of brake spring	9
3-4 Removal of sinker plate	9
3-5 Disassembly of the needlebed base unit	10
3-6 Assembly of needlebed base unit	11
[4] ASSEMBLY OF NEEDLEBED	
4-1 Installation of the sinker plate	14
4-2 Installation of brake spring, front rail and rear rail	14
4-3 Installation of the needlebed A	16
[5] ADJUSTMENT OF EACH PART OF NEEDLEBED	
5-1 Adjustment of needlebed A, B (R/L)	19
5-2 Adjustment of the rear rail A, B (R/L)	20
5-3 Adjustment of needlebed rack	20
5-4 Adjustment of lock lever	21
5-5 Installation of tension set and pattern panel	21
[6] DISASSEMBLY, ADJUSTMENT AND INSTALLATION OF PATTERN	
6-1 Disassembly of the pattern	23
6-2 Cares to be taken for installing pin drum and feed ratchet	24
6-3 Method of adjustment for punchcard hole and touch-lever projection ...	24
6-4 Installation of the pattern	25
6-5 Adjustment of the feed lever	26
6-6 Installation of feed dial and row counter	27
[7] DISASSEMBLY, ADJUSTMENT AND INSTALLATION OF CARRIAGE	
7-1 Disassembly of carriage (to the removal of the carriage cover) ...	28
7-2 Adjustment of the drum	29
7-3 Adjustment of clear wire	31
[8] SIZES OF EACH PART & ADJUSTMENT OF ARM	32
[9] HOW TO FIX UP OTHER INDEQUATE PLACES	33
CAUSES FOR INDEQUATE STORAGE [1]	34
CAUSES FOR INDEQUATE STORAGE [11]	35
STANDARD SIZE FOR MAIN CAM	36

[1] OUTLINE OF MODEL HK-160

1-1 MAIN SPECIFICATIONS FOR THE MACHINE

	HK-160	Conventional machines
(1) Machine		
*Pitch	6.0mm	(4.5mm)
*No. of needles	160	(200)
*Latch Needles	short needle with 3.8mm hook	(long needle with 3.3mm hook)
*Needle selection	punchcard system	(punchcard system)
*Unit of needle selection	18 needle selection	(24 needle selection)
(2) Dimension		
*Length	1,096mm	(1,110mm)
*Width	234mm	(250mm)
*Height	630mm	(710mm)
(3) Weight		
*Gross weight of machine	10.0kg	(12.5kg)
*When packaged	11.3kg	
(4) Knitting		
Stitch Types:	stokinet, two-color knit-in, slip stitch, tuck stitch, cord stitch	
Yarn usable:	light yarn, medium yarn and thick yarn	
Cast-on		
(5) Form		
Needlebed:	made of plastics, integrally molded with needle slot and rack	
Tension:	same as conventional machines	
Arm:	folded storing system	

1-2 LUBRICANT AND CLEANING SOLVENT

- (1) Lubricants and cleaning solvents usable
 - oil supplied with the machine (liquid paraffin)
 - neutral detergent
 - alcohol (ethyl alcohol)
- (2) Lubricants and cleaning solvents not applicable
 - alcohol (methyl alcohol)
 - thinner
 - benzine
- (3) Lubricants and cleaning solvents usable only if applied in proper amount (should not be applied too much)
 - spindle oil (available from the supplier of the machine)
 - Knitting-super
 - Car-unicorn

[2] CAUTION

Care should be taken to avoid leaving for a long time in a car during hot summer season, exposing to direct sun-light, or storing at a place with high humidity or with wide temperature variations in order to prevent elongation or distortion of the needle bed and other plastic made parts.

[3] DISASSEMBLY OF NEEDLEBED

3-1(A) DISASSEMBLY OF THE NEEDLEBED A

(note) Disassembling procedure described below are not required for the disassembly of the needlebed B (R/L).

- (1) Remove the pattern panel lifting it up with both hands following the procedure of Fig. 2.

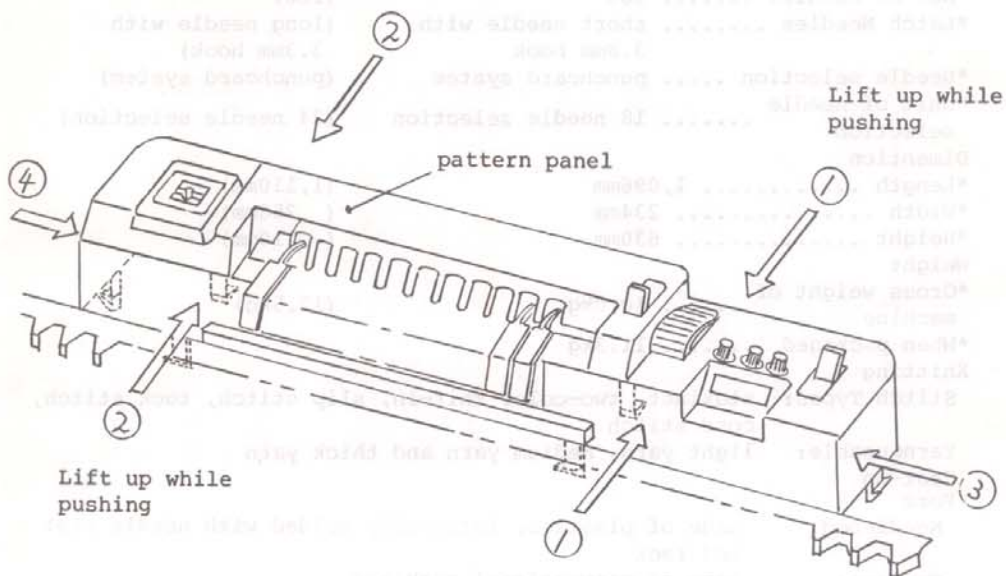

(Fig. 1)

- (2) As shown in Fig. 2, loosen a truss tapping type 2 which fastens the tension set.

⊕truss tapping screw
(3 x 10)

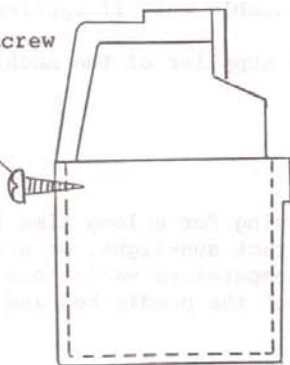

(Fig. 2)

3-1 (B) Turn over the needle bed as shown and remove the screws securing the hinge fixing plates (R,L.) for the needle bed A and B.

(Note) Care should be taken to avoid losing plain washers between the hinge fixing plates and the needle bed B.

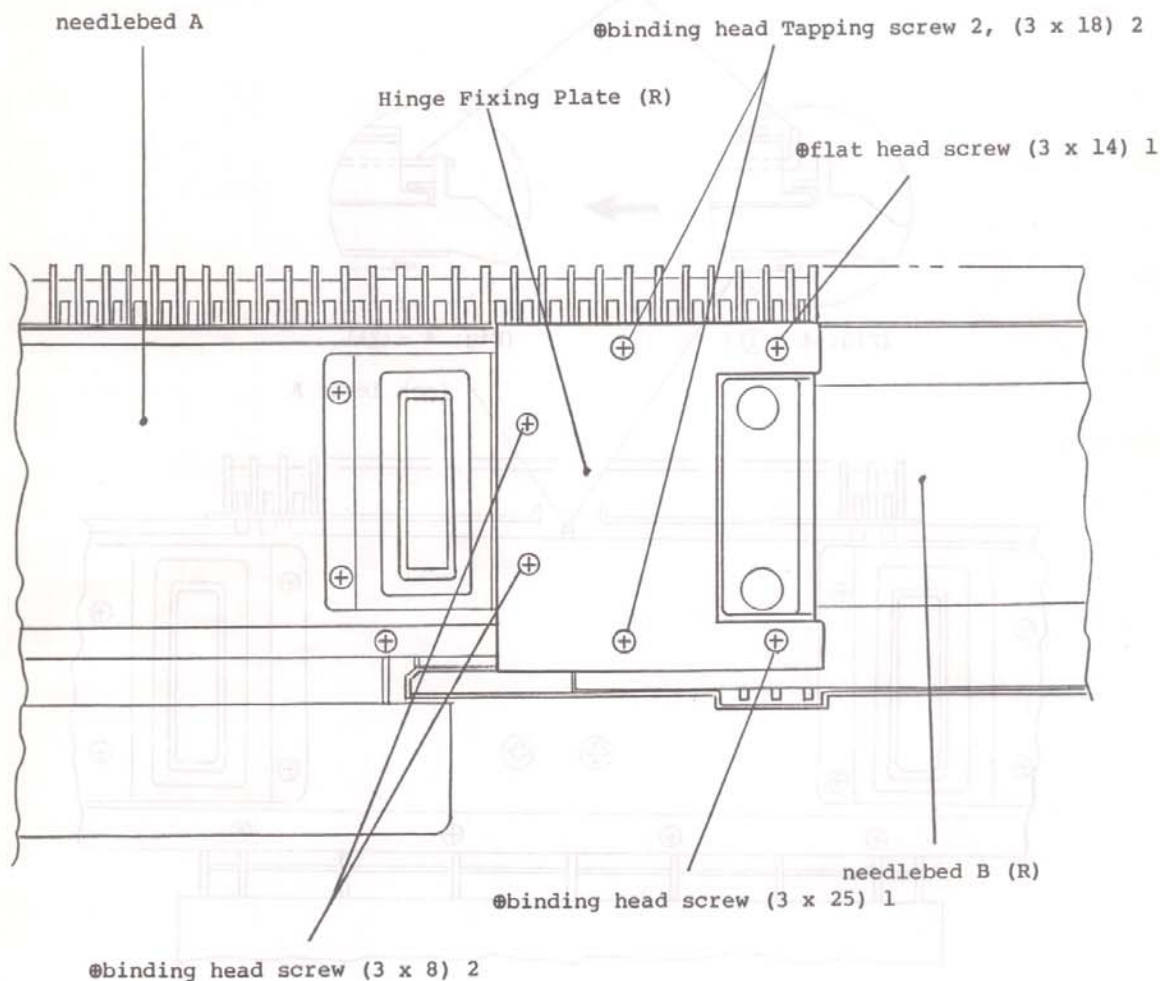

(Fig. 3)

- 3-1 (C) 1. Turn over the needle bed as shown (Fig. 4-1)
2. Straighten the bend of the lock lever A by radio pliers etc. (Fig. 4-① → Fig. 4-②)
- (Note) Lock lever must be bent after assembling has been finished.

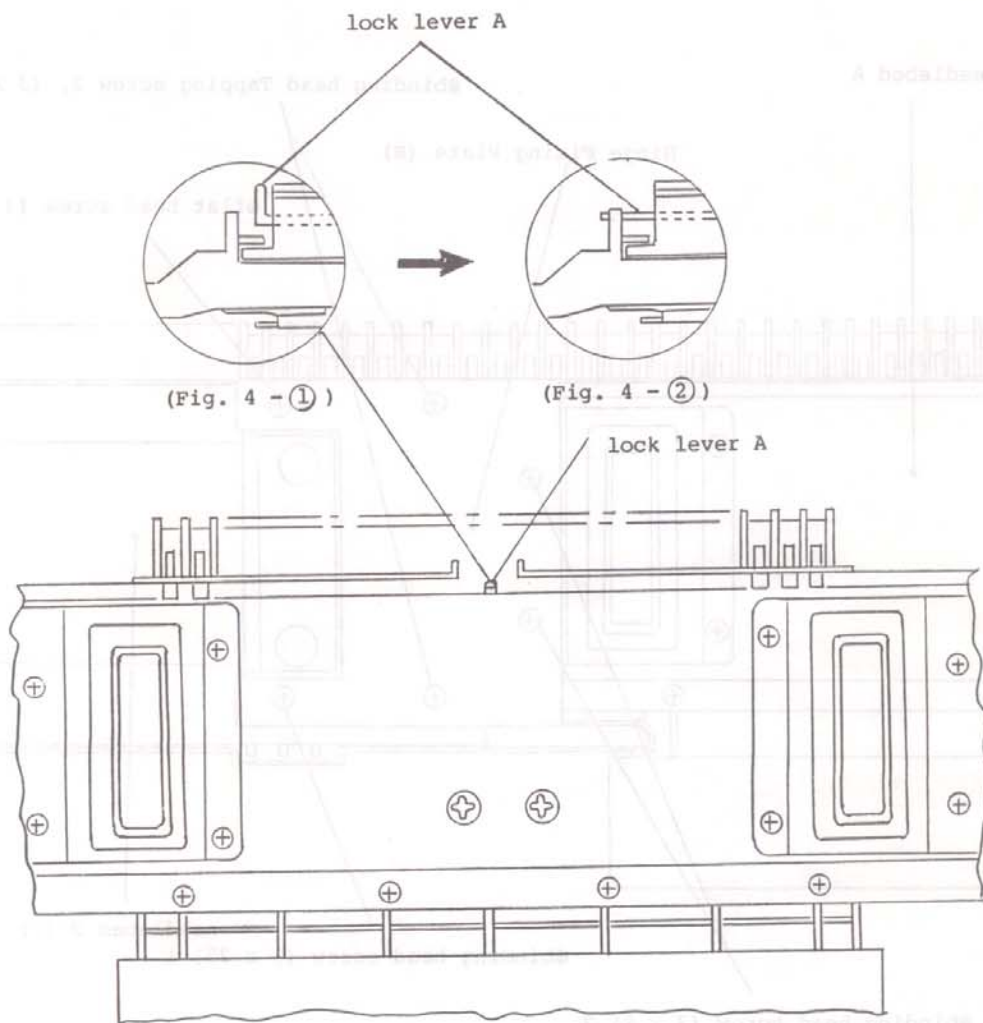

(Fig. 4 - 1)

- 3-1 (D) 1. Turn it over again, push the lock lever A and raise the needle bed B (R,L) as shown.
2. After removing the screws securing the needle bed B (R,L), needle bed B (R,L) come off from the hinges.

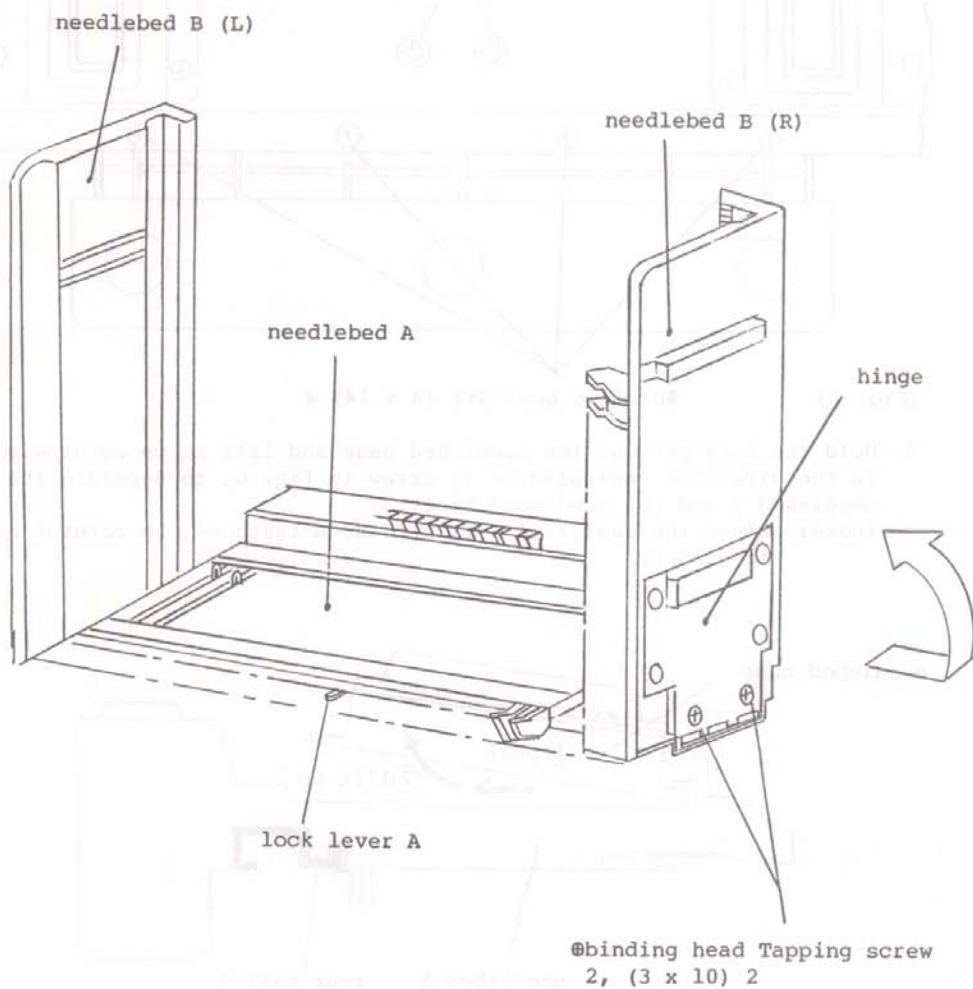

(Fig. 4 - 2)

- (4) 1. After removing the needlebed B (R/L), reverse the needlebed A as in Fig. 5 and take off the front rail A, the needlebed base, and 4 ⊕ bind STT (3 x 14) which are fastening the needle bed A.
(It is better to keep the hinge in locked position.)

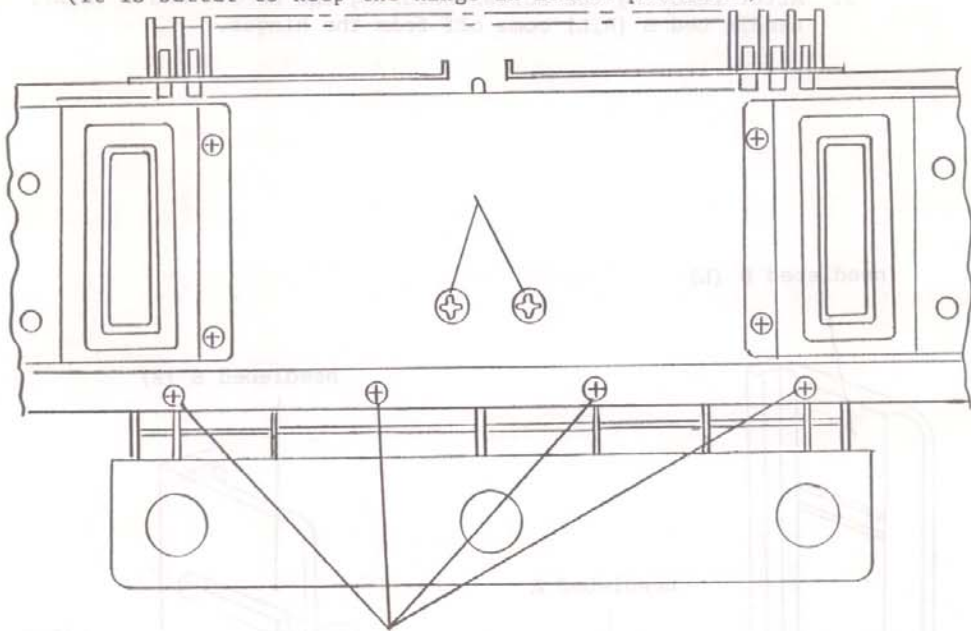

(Fig. 5) ⊕binding head STT (3 x 14) 4

2. Hold the back part of the needlebed base and lift it up as drawing it in the direction indicated by an arrow in Fig. 6, to separate the needlebed A and the needlebed base.
(note) Since the rear rail A is already unfastened, be careful not to drop it.

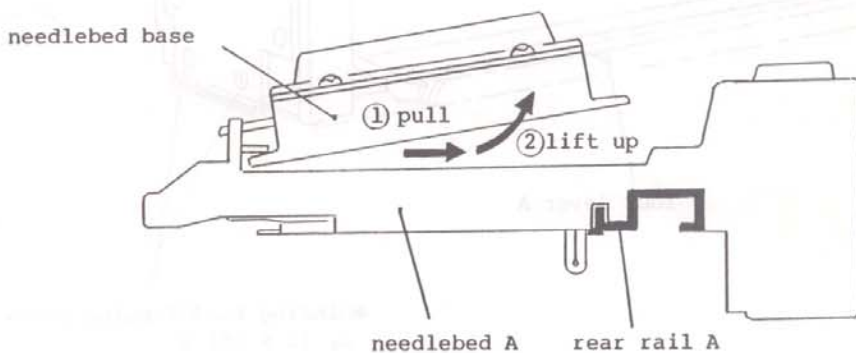

(Fig. 6)

3-2 REMOVAL OF THE FRONT RAIL, REAR RAIL, AND PLATE SPRING
 (note) This is applicable only for the needlebed B (R/L).

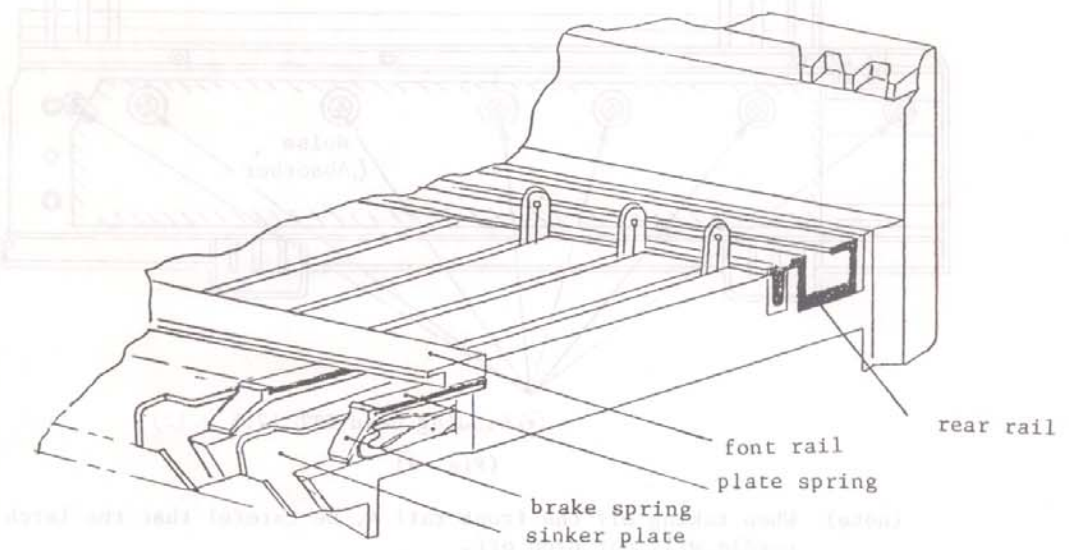

(Fig. 7)

- (1) Remove the needlebed B (R/L) from the hinge, and also take off 2 ⊕ binding tapping type 2 (3 x 10) and 2 ⊕ binding head STT (3 x 16) which are fastening the needlebed cover (R/L) and the plate support.

(note) As for the needlebed A, refer to the preceding section "disassembly of needlebed A" to take off the needlebed A from the needlebed base.

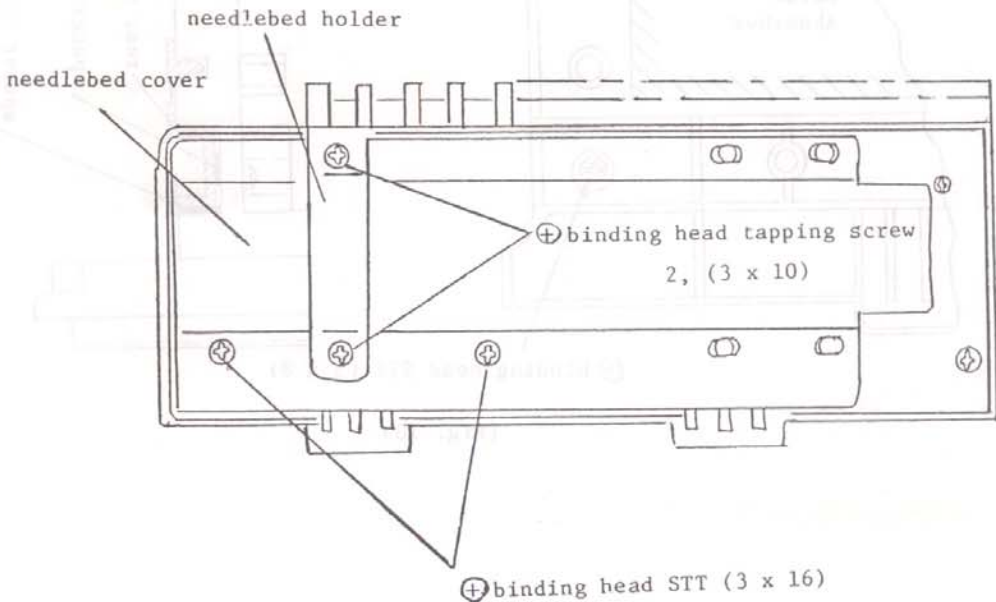

(Fig. 8)

- (2) Take off 7 ⊕ bind STT (2.5 x 12) which are fixing the front rail B (R/L) to remove the front rail B (R/L) and the plate spring.
 (As for the front rail A, take off 8 ⊕ bind STT (2.5 x 12).)

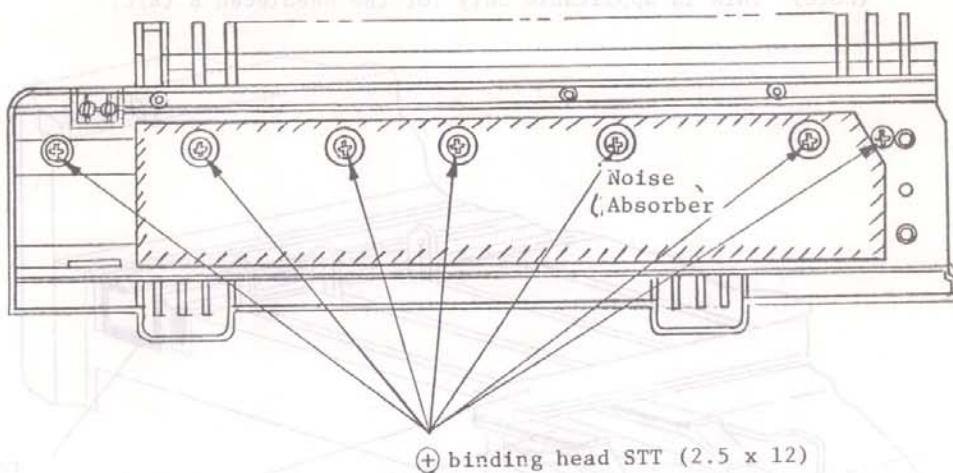

(Fig. 9)

(note) When taking off the front rail A, be careful that the latch needle will not drop off.

- (3) Remove a ⊕ bind STT (3 x 8) which is fastening the rear rail B (R/L) to take off the rear rail B (R/L).
 Be careful not to lose the adjusting washer which to adjust the height of the rear rail and also the needlebed rack adjusting spacer, if any.

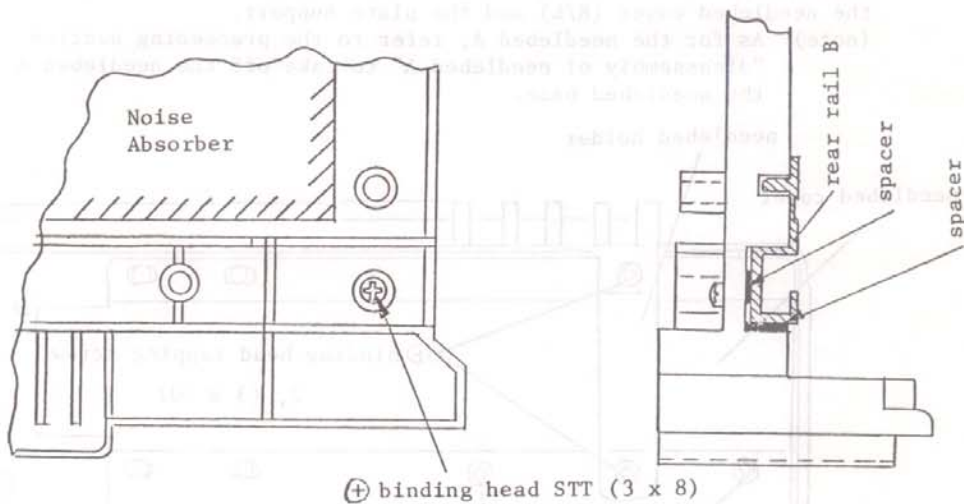

(Fig. 10)

3-3 REMOVAL OF BRAKE SPRING

The brake spring can be removed by extruding the latch needle (which exists just about the center of the brake spring) as far as the \diamond mark and lifting up the butt.

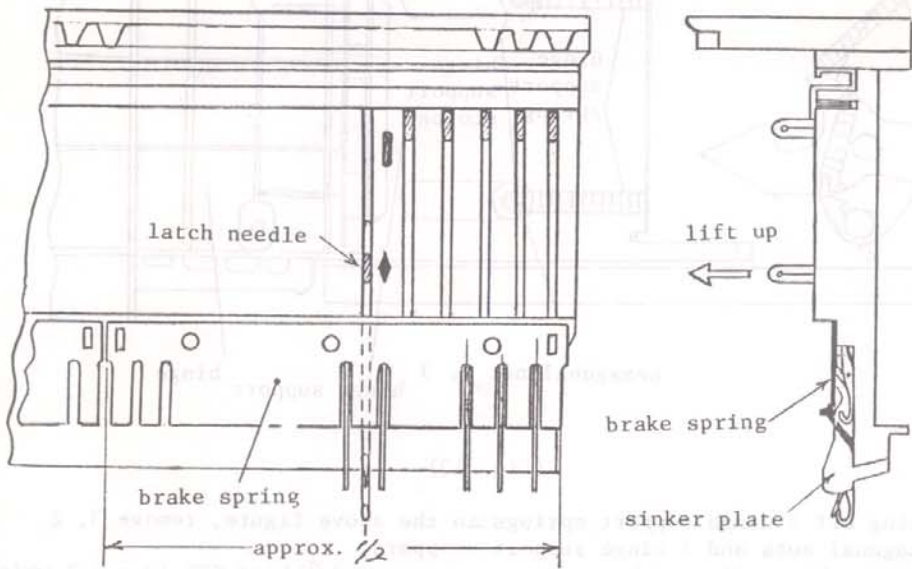

(Fig. 11)

3-4 REMOVAL OF SINKER PLATE

The back part of the sinker plate is lifted up, when the tip of the sinker plate is finger pressed strongly. (Fig. 1) The sinker plate can be removed (Fig. 2) then, from the needlebed by pulling the tip of it forward. (Fig. 3)

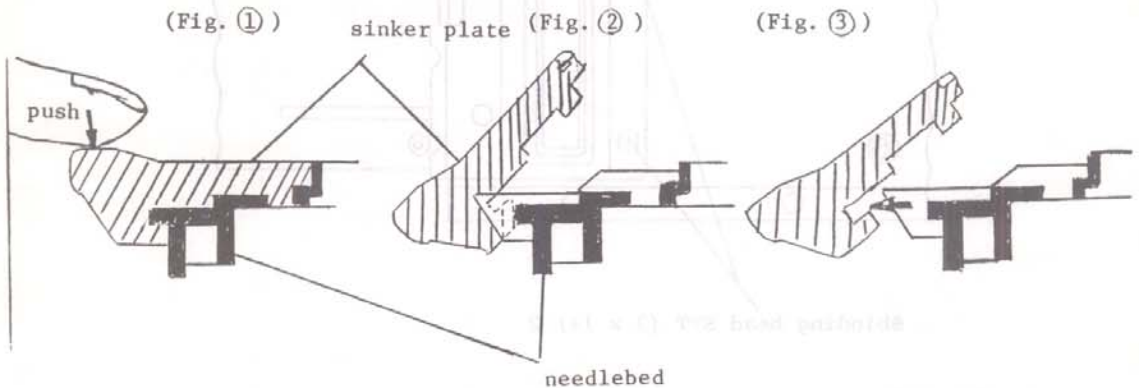

(Fig. 12)

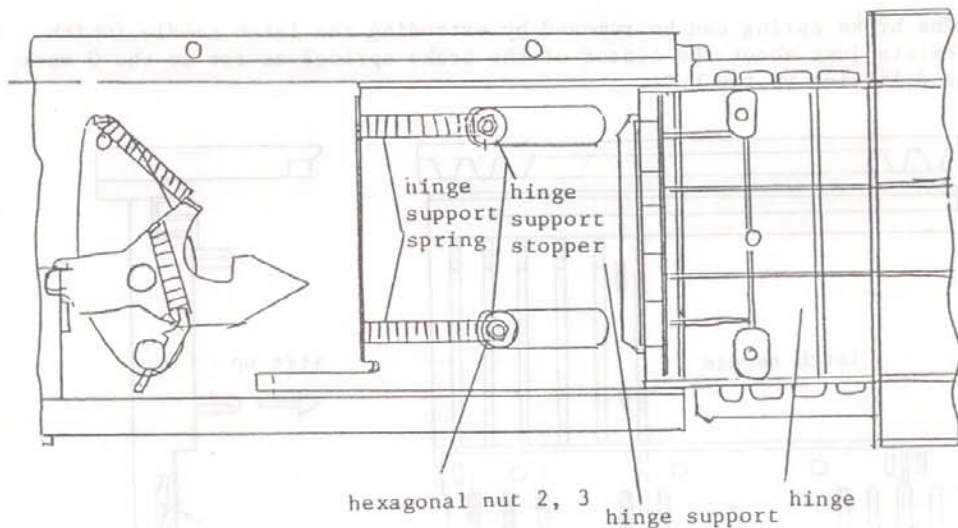

(Fig. 13)

- (1) Taking off 2 hinge support springs in the above figure, remove 3, 2 hexagonal nuts and 2 hinge support stoppers.
- (2) Reverse the needle bed base unit, and remove 2 ⊕ bind STT (3 x 14) which are fastening the clamp receptacle.

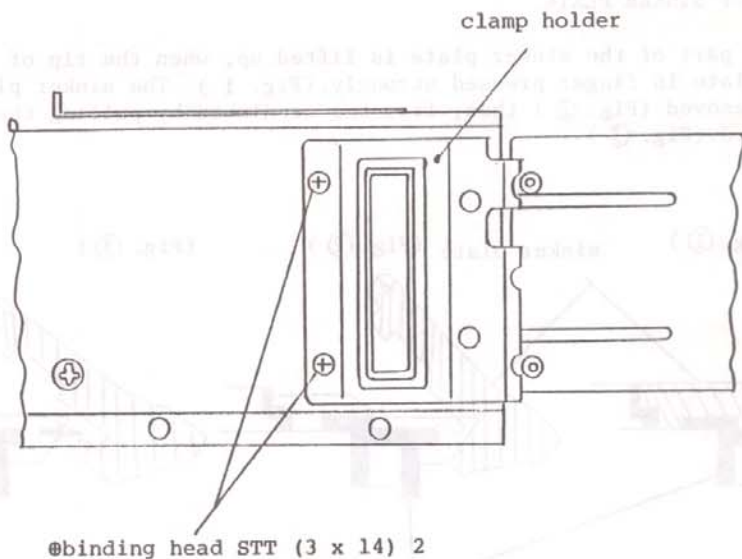

(Fig. 14)

- (3) The hinge support is drawn out together when drawing out the hinge from the needlebed base.
The hinge and the hinge support can be detached by pulling out the hinge pin which connects the hinge and the hinge support.
(note) There is also a plane washer for adjustment.

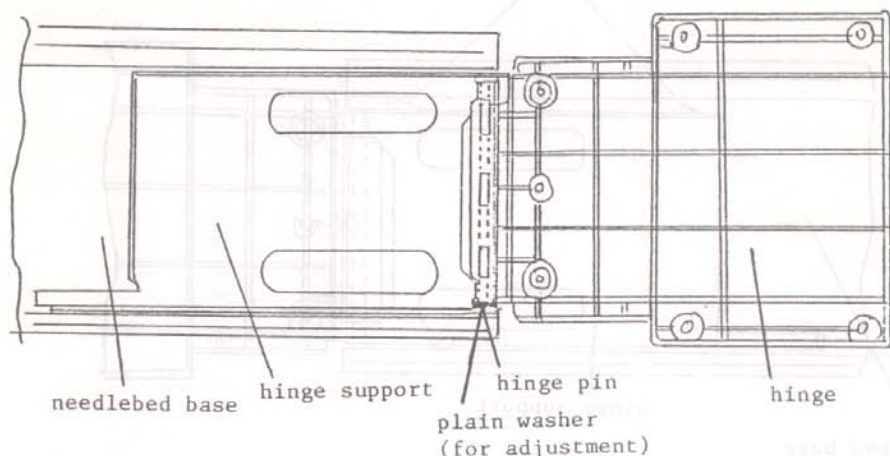

(Fig. 15)

3-6 ASSEMBLY OF NEEDLEBED BASE UNIT

- (1) Connect the hinge and the hinge support with the hinge axis, by adjusting with the adjusting plane washer so that there is no gap between the hinge and the hinge support.

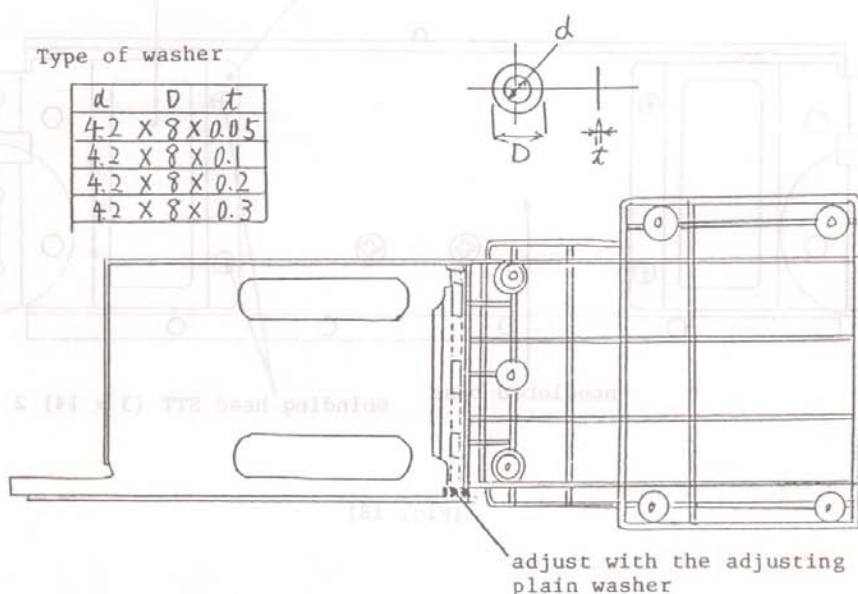

(Fig. 16)

- (2) Install the needlebed base and the hinge set with the use of a wrench or pliers so as to make approx. 0 - 0.1mm of gap between them.

make approx. 0 - 0.1mm of gap between needlebed base and hinge

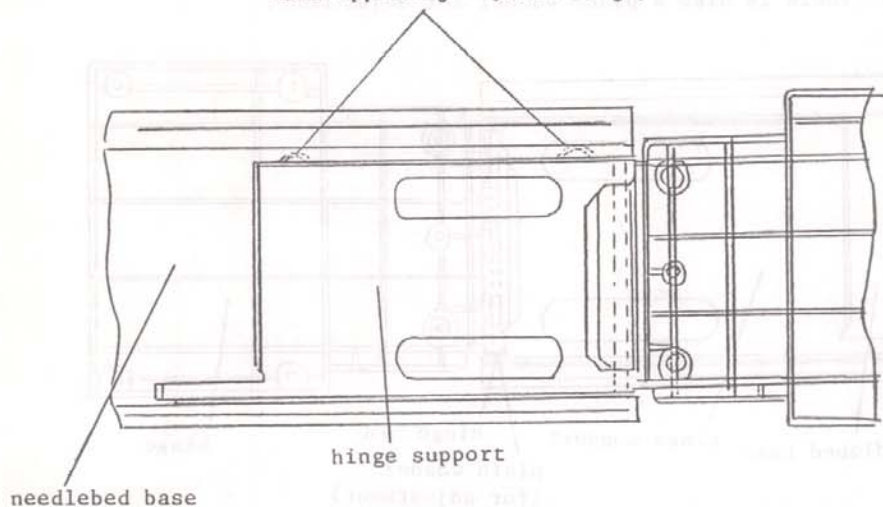

(Fig. 17)

- (3) When installing the clamp receptacle (R/L), be sure to check whether it's R or L before fixing them with screws.

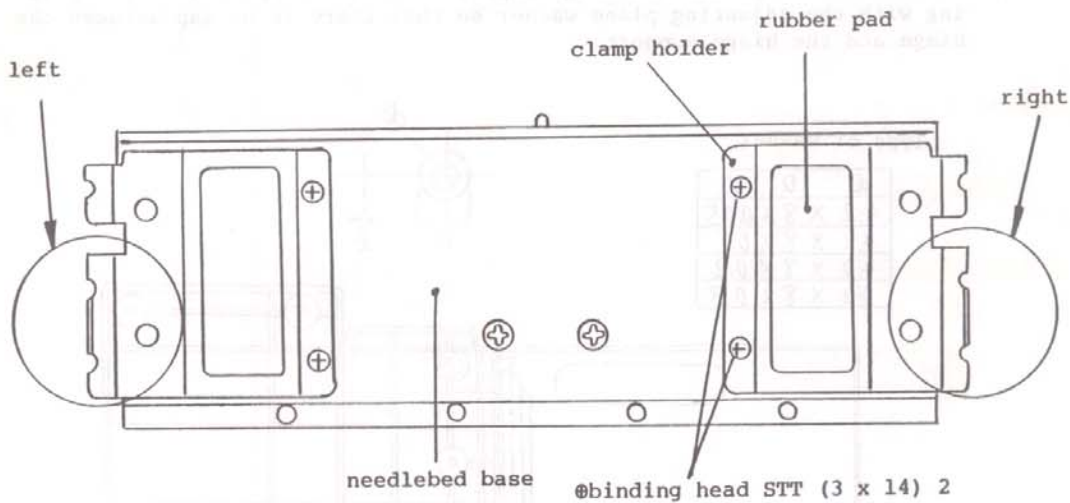

(Fig. 18)

- (4) After installing the clamp receptacles (R/L); fix the hinge support stopper, 3 type 2 hexagonal nuts, and then the hinge support spring.

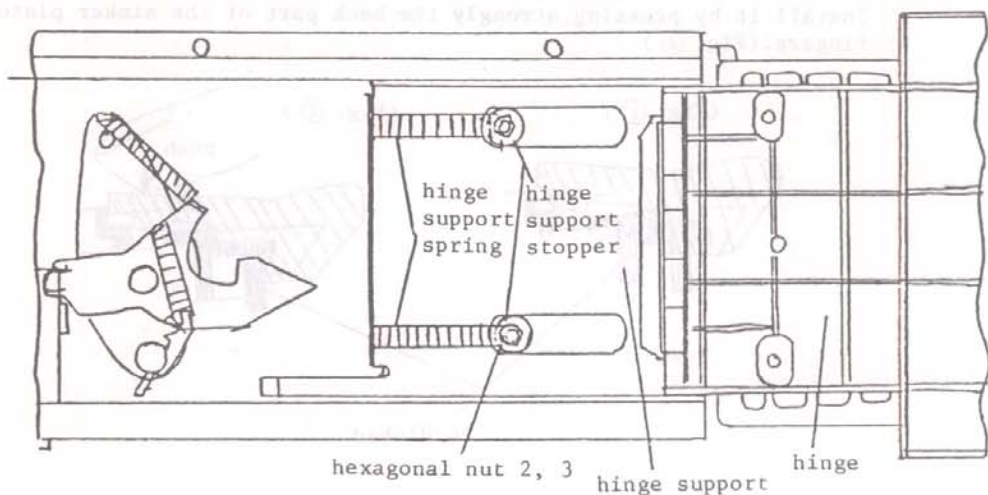

(Fig. 19)

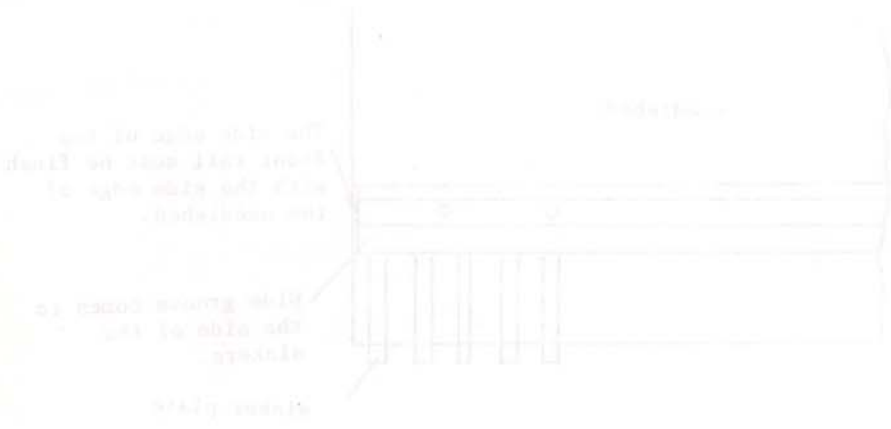

[4] ASSEMBLY OF NEEDLEBED

4-1 INSTALLATION OF THE SINKER PLATE

Insert the sinker plate into the groove of the needlebed. (Fig. ①)
Install it by pressing strongly the back part of the sinker plate with fingers. (Fig. ②)

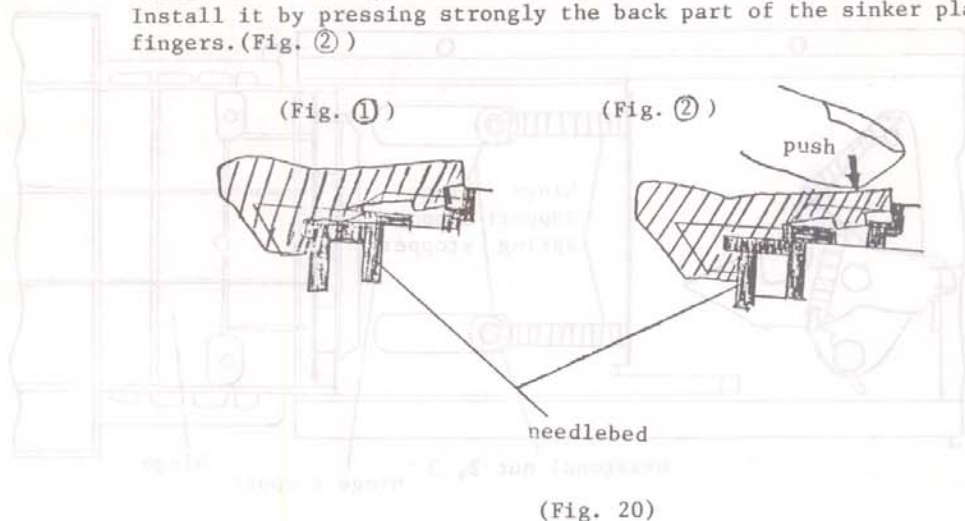

4-2 INSTALLATION OF BRAKE SPRING, PLATE SPRING, FRONT RAIL, AND REAR RAIL

- (1) Insert the brake spring into the brake spring fixing groove of the needle bed.
- (2) Place down the plate spring on the brake spring, and tighten the front rail A, B (R/L) from the inside with 6 STT (2.5 x 12) A, and 5 of B.
(note) Be careful not to mistake R for L of the front rail B, and also not projecting the front rail out of the needlebed sides.

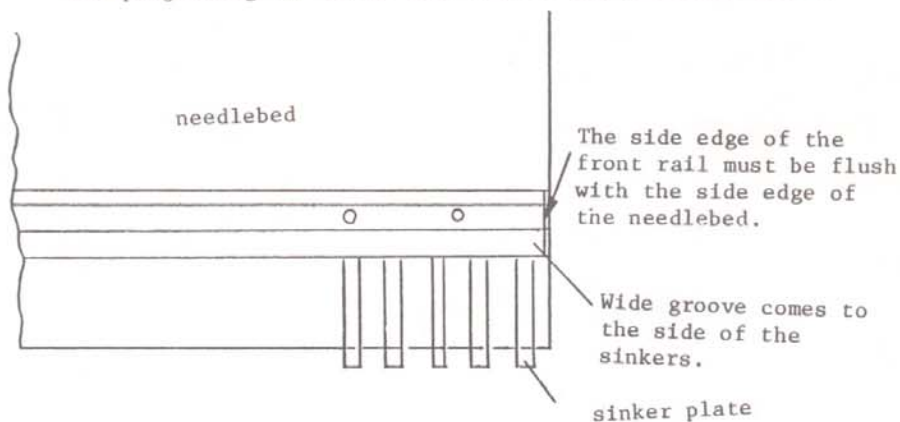

- (3) Fix the rear rail B (R/L) with a \oplus bind STT (3 x 8), overlapping it to the side of the needlebed and pressing it to the sinker plate.

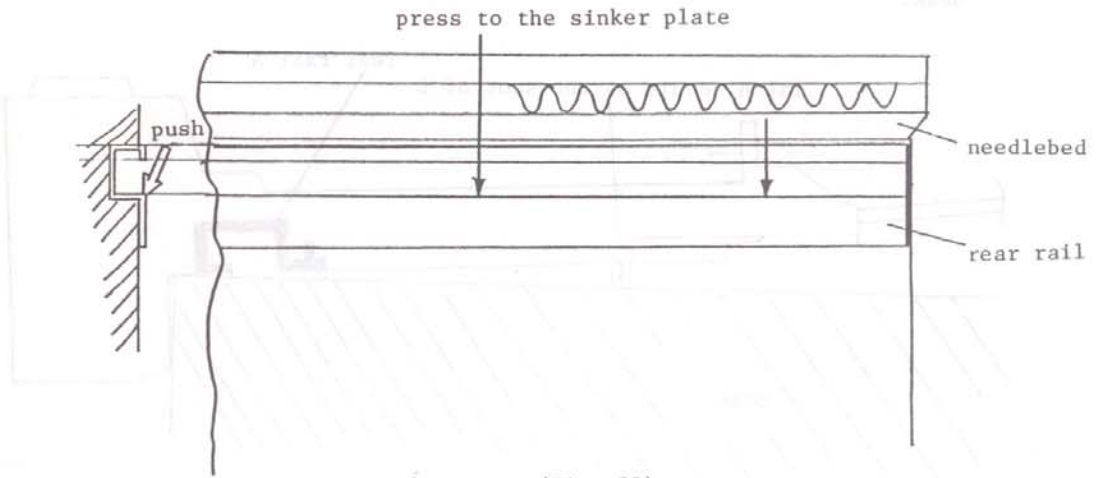

(Fig. 22)

- (4) Install the needlebed cover and the needlebed support with using 2 \oplus bind STT (3 x 16) and 2 \oplus bind tapping type 2 (3 x 10).

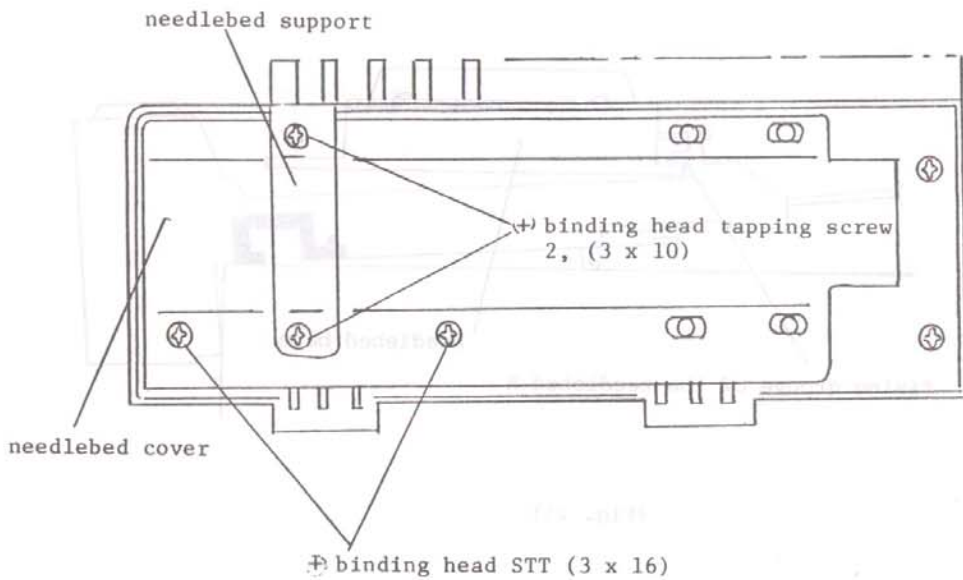

(Fig. 23)

4-3 INSTALLATION OF THE NEEDLEBED A

- (1) Push the latch needles on the needle bed A to D position, place the rear rail A on the needle bed A, and turn the needle bed over on the desk.

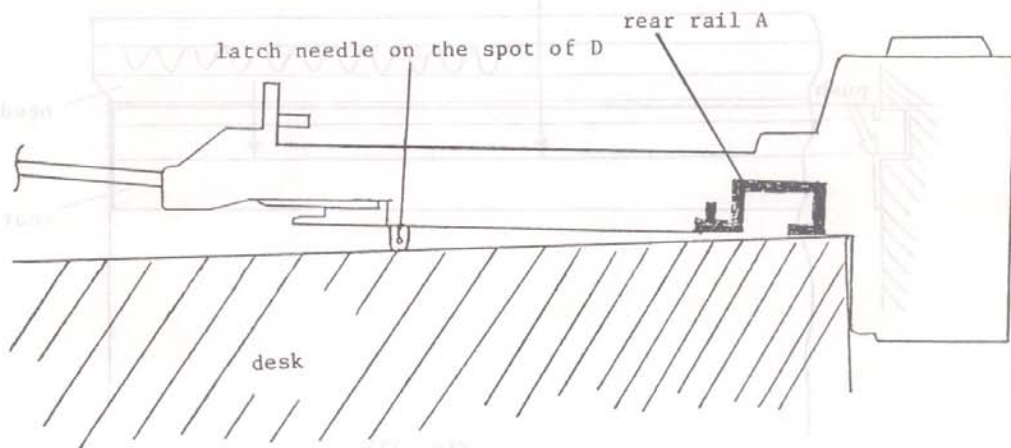

(Fig. 24)

- (2) Insert the needlebed base into the fixing groove of the needlebed A.

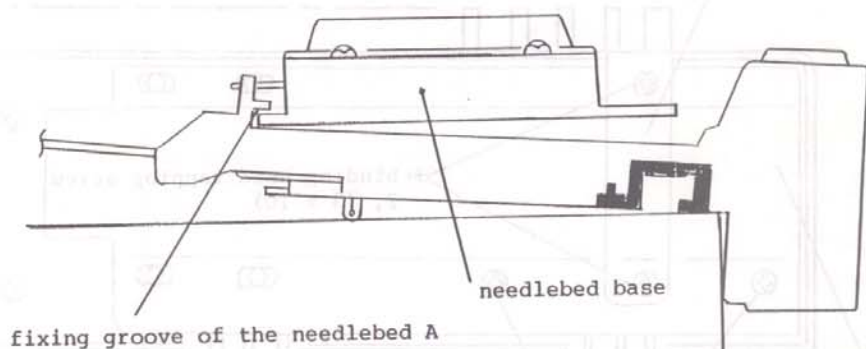

(Fig. 25)

- (3) Place the needlebed base and fix the rear rail A temporarily with 4 $\text{\textcircled{+}}$ binding head STT (3 x 14)

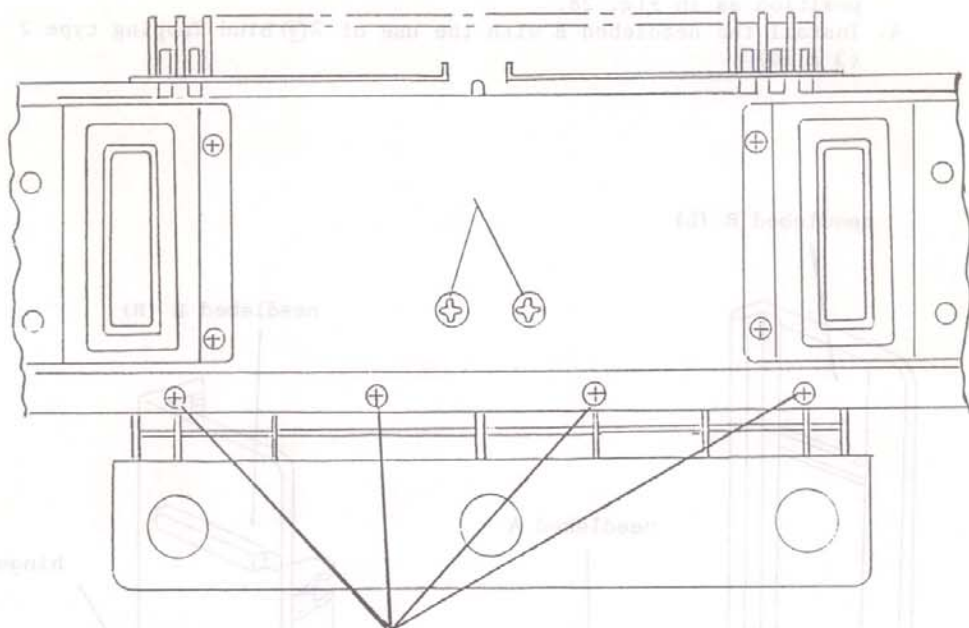

(Fig. 26) $\text{\textcircled{+}}$ binding head STT (3 x 14) 4

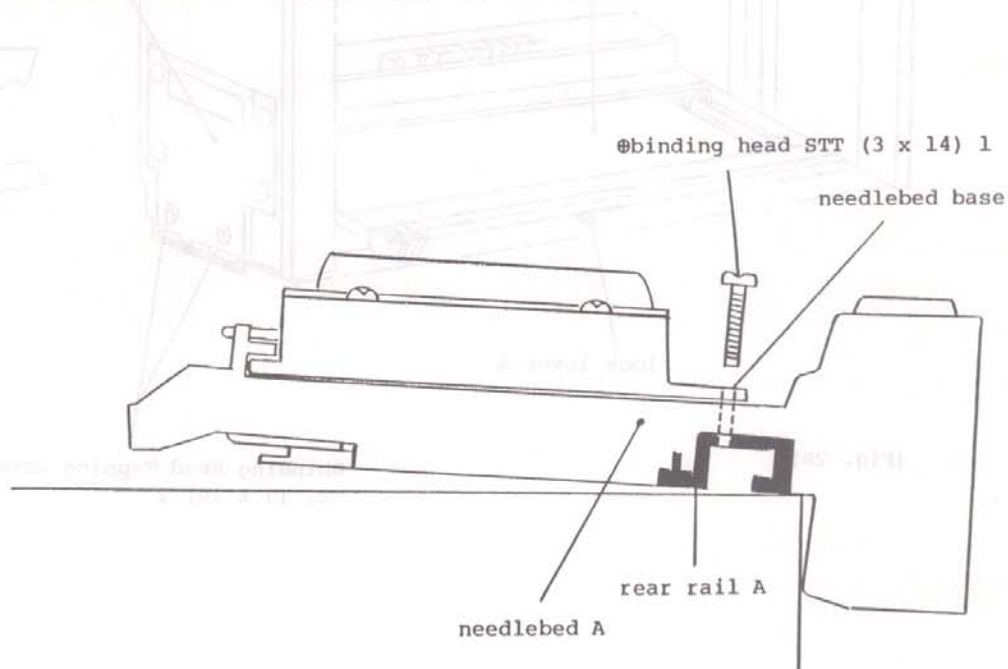

(Fig. 27)

- (4) 1. Press the lock lever A to draw out left and right hinges.
2. Fix the needlebed B on the hinge.
3. Raise both ends vertically with the hinge and the needlebed B in fixed position as in Fig. 28.
4. Install the needlebed B with the use of 2 ⊕ binding head Tapping type 2 (3 x 10).

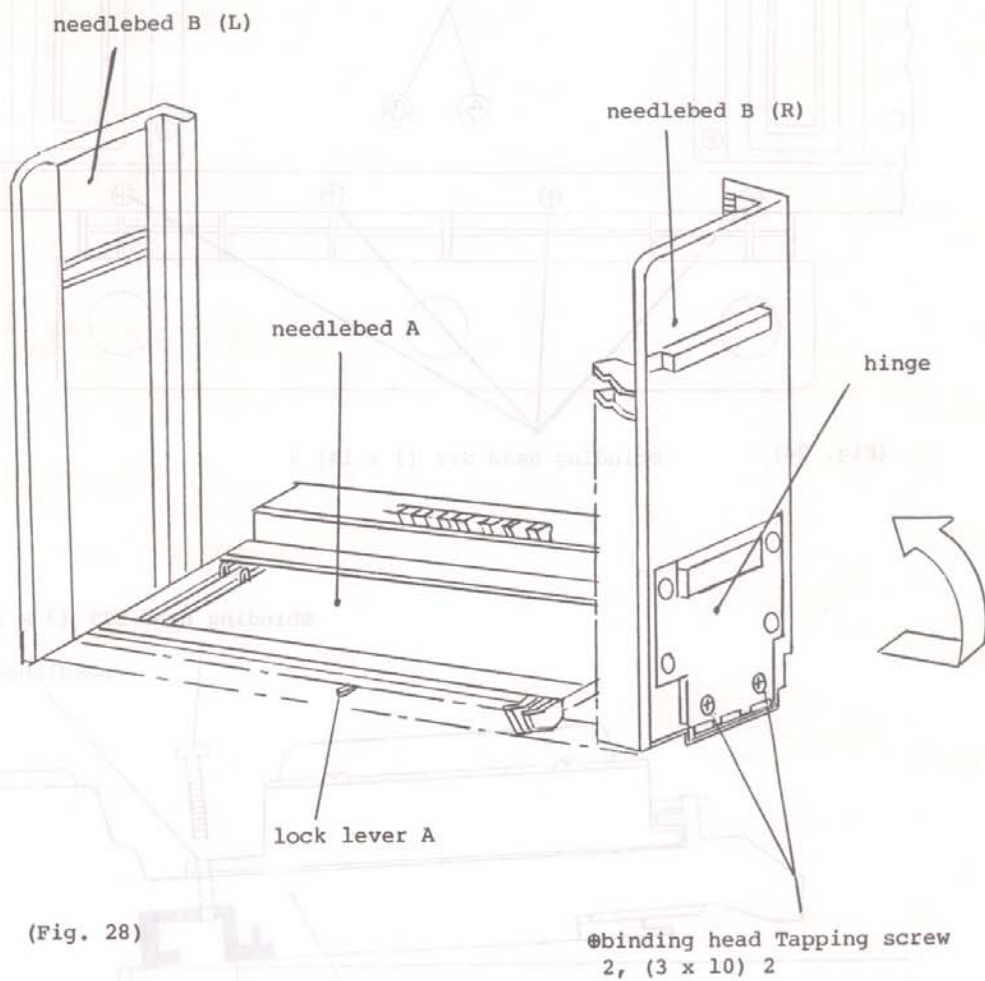

[5] ADJUSTMENT OF EACH PART OF NEEDLEBED

5-1 ADJUSTMENT OF NEEDLEBED A, B (R/L)

- (1) Lock the needlebed B (R/L) with the needlebed A. Tighten 4 + bind STT (3 x 14) which have been temporarily fixed in the preceding section 4-3(3), adjusting the position of the needlebed A so that the rear rail A and the front rail A become parallel to the rear rail B (R/L) and front rail B (R/L) respectively when locked.

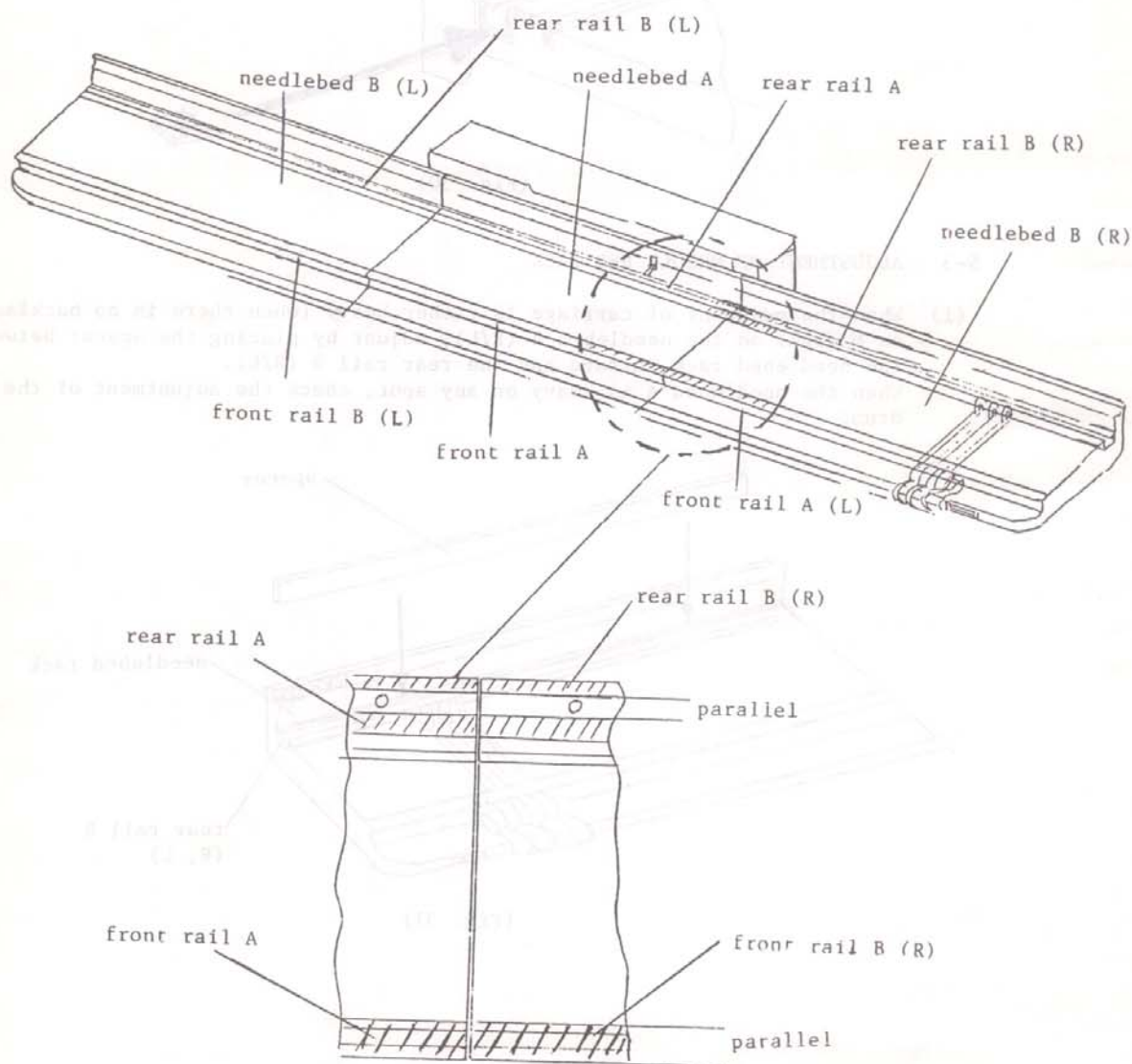

(Fig. 29)

5-2 ADJUSTMENT OF THE REAR RAIL A, B (R/L)

- (1) If there is any difference in height between the rear rail B (R/L) and rear rail A, loosen one \oplus bind STT (3 x 14) and adjust the height by using adjusting washers (plain washer) between the needlebed A and the rear rail B.

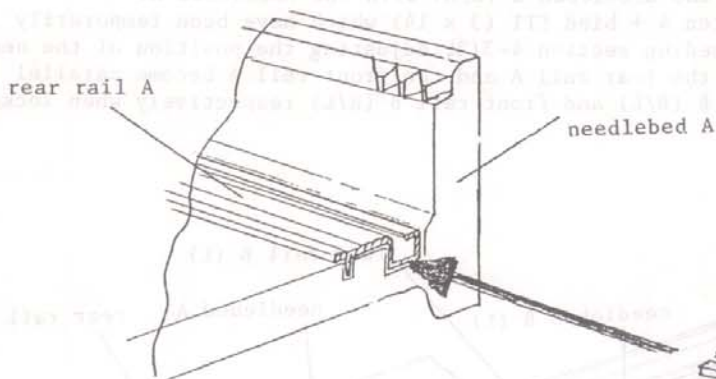

(Fig. 30)

5-3 ADJUSTMENT OF NEEDLE BED RACK

- (1) When the movement of carriage is rather heavy (when there is no backlash on M drum) on the needlebed B (R/L), adjust by placing the spacer between the needlebed rack surface and the rear rail B (R/L). When the needlebed A is heavy on any spot, check the adjustment of the drum.

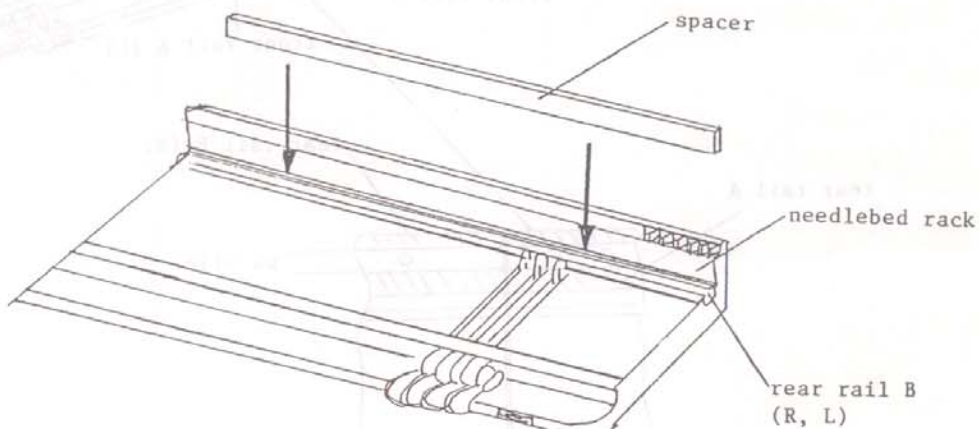

(Fig. 31)

5-4 ADJUSTMENT OF LOCK LEVER

- (1) When locking the lock lever; pushing the lock button by approx. 1.0mm, tighten 2 bind small screws (4 x 8) by pressing them all the way through in the direction of an arrow.
When the adjustment is inadequate,
 1. Lock is not done adequately, when locking needlebed B (R/L).
 2. The needlebed (R/L) is not detached from the needlebed by the lock lever A being pressed and released.

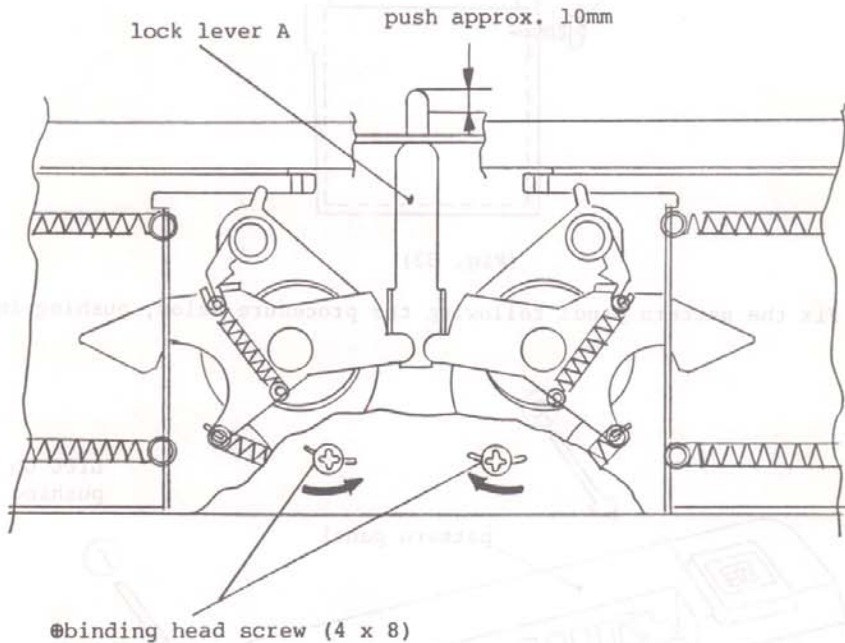

(Fig. 32)

5-5 INSTALLATION OF TENSION SET AND PATTERN PANEL

The tension set and the pattern panel are installed after the adjustment of each part of the needlebed mentioned in [5] is over.

- (1) Insert the tension set into the needlebed A.

(1) When locking the lock lever, push the lock lever by spring force. Lightly turn the lock lever in a clockwise direction. When the adjustment is complete, push the lock lever in the direction of an arrow. When the adjustment is complete, push the lock lever in the direction of an arrow. The lock is now ready for use. The adjustment is complete. The lock is now ready for use.

@truss tapping screw
(3 x 10)

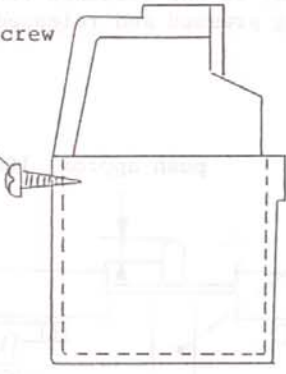

(Fig. 33)

(2) Fix the pattern panel following the procedure below, pushing inwardly.

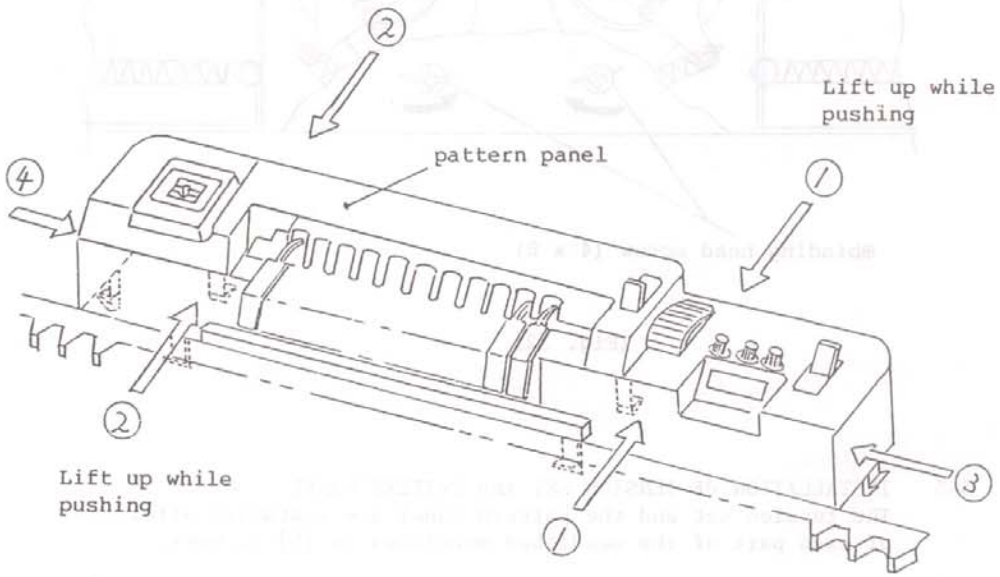

(Fig. 34)

[6] DISASSEMBLY, ADJUSTMENT, AND INSTALLATION OF PATTERN

6-1 DISASSEMBLY OF THE PATTERN

- (1) Take off the row counter by removing one ⊕ bind tapping type 2 (3 x 10) which fastens the row counter.
- (2) Remove the feed dial out of the pattern shaft.
- (3) Remove the pattern out of the needlebed A, by taking off 4 ⊕ bind tapping Type 2 (3 x 10) which fasten the pattern.
- (4) Insert the minus screwdriver into the clearance between the feed ratchet and the feed lever stand to remove the feed ratchet from the pattern shaft.

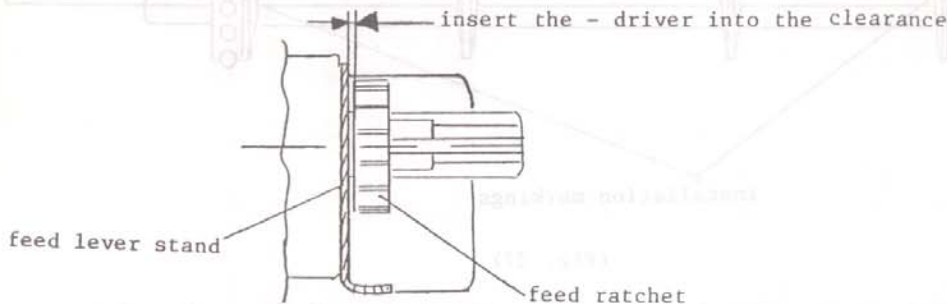

(Fig. 35)

- (5) The feed lever stand unit can be taken off by removing 2 ⊕ bind tapping Type 2 (3 x 10) which fasten the feed lever stand.

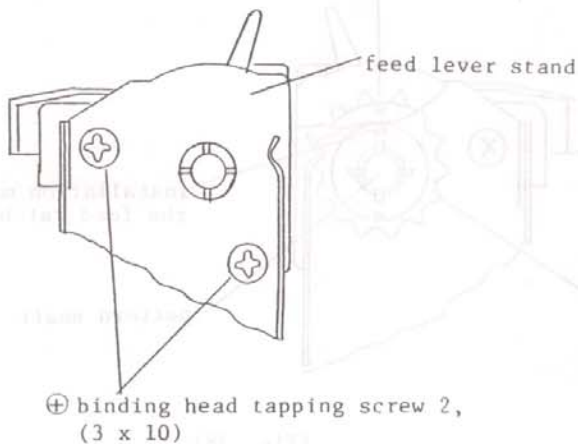

(Fig. 36)

6-2 CARES TO BE TAKEN FOR INSTALLING PIN DRUM AND FEED RATCHET

- (1) Pindrum shall be installed to the pattern shaft so that the installation markings of right and left sides of the drums meet together.
If not so, the punchcard is going to be slanted

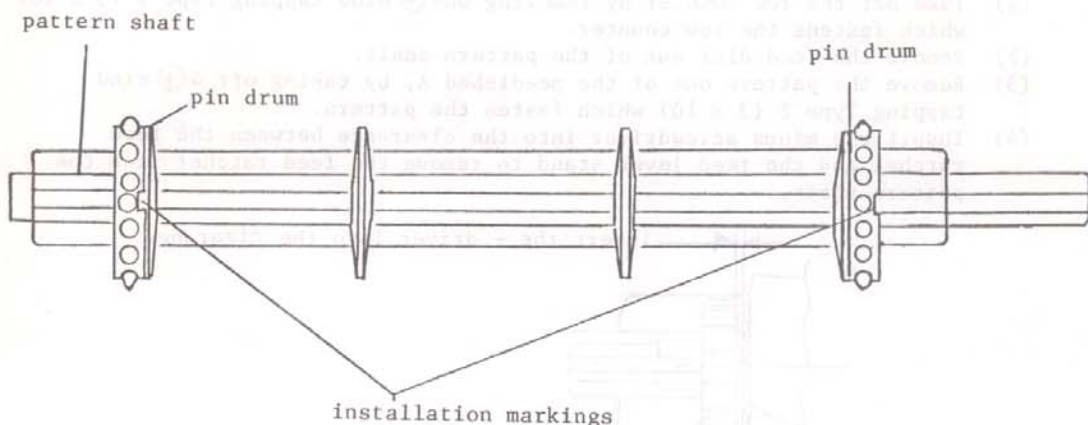

(Fig. 37)

- (2) The feed ratchet shall be installed to the pattern shaft so that the installation marking of the feed ratchet and that of the pin drum meet together.

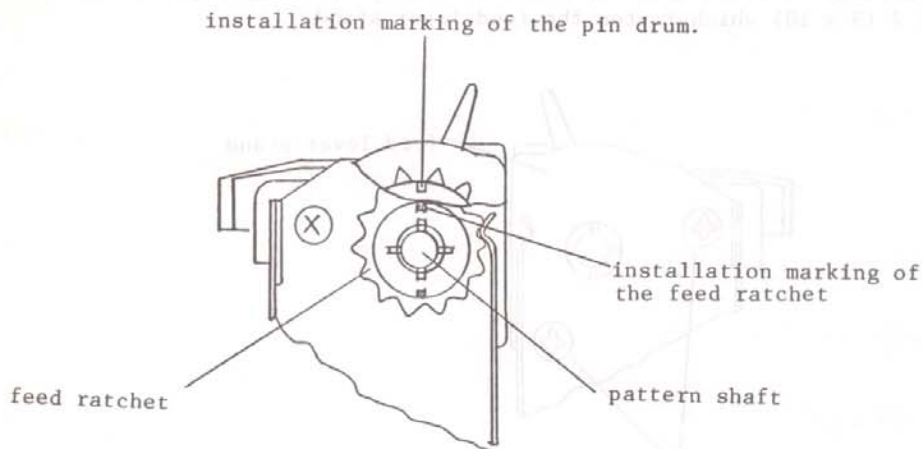

(Fig. 38)

6-3 METHOD OF ADJUSTMENT FOR PUNCHCARD HOLE AND TOUCH-LEVER PROJECTION

- (1) Set the No. 1 punchcard (which is easy to read) on the pattern
- (2) Ensure that the projection of the touchlever enter freely into the hole of the punchcard, when it pushed into.
- (3) In case that the projection of the touchlever does not come to the center of the hole of the puchcard, loosen one \oplus bind STT (3 x 6) which is on the reversed side of the pattern box and is fastening the stop lever spring.

- (4) Adjust by moving the stop lever spring as shown by an arrow, watching the hole of the punchcard and the projection of the touch lever.

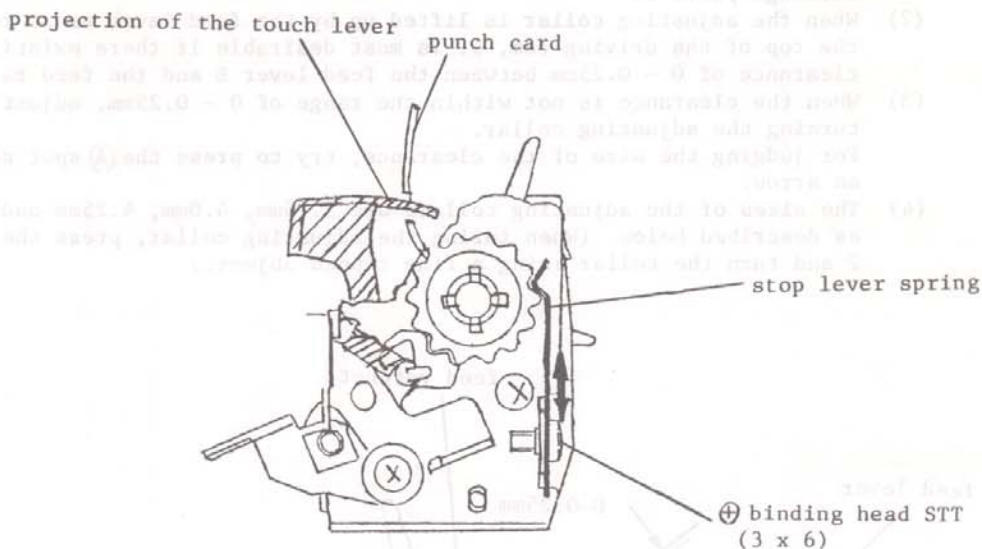

(Fig. 39)

6-4 INSTALLATION OF THE PATTERN

- (1) Fasten the pattern temporarily on the nedlebed A with the use of 4 ⊕ bind tapping Type 2 (3 x 10).
- (2) Shift the pattern transversely so that the M drum piece comes to the center of the touch lever, and tighten the screw.

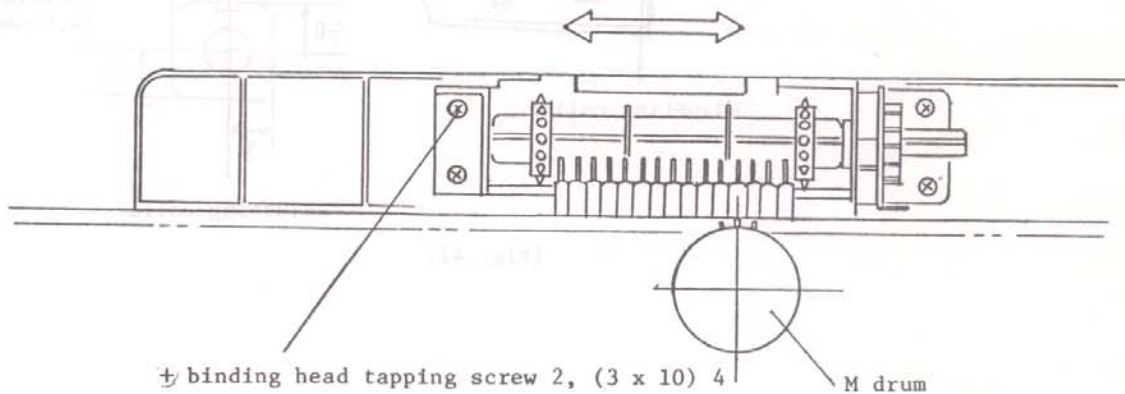

(Fig. 40)

6-5 ADJUSTMENT OF THE FEED LEVER

- (1) The feed lever is operated by the driving cam on the back of the carriage plate B.
- (2) When the adjusting collar is lifted up by the feed lever as it reaches the top of the driving cam, it is most desirable if there existing the clearance of 0 - 0.25mm between the feed lever B and the feed ratchet.
- (3) When the clearance is not within the range of 0 - 0.25mm, adjust it by turning the adjusting collar.
For judging the size of the clearance, try to press the (A) spot shown by an arrow.
- (4) The sizes of the adjusting collars are 3.75mm, 4.0mm, 4.25mm and 4.5mm as described below. (When tuning the adjusting collar, press the spot 2 and turn the collar using a fine tipped object.)

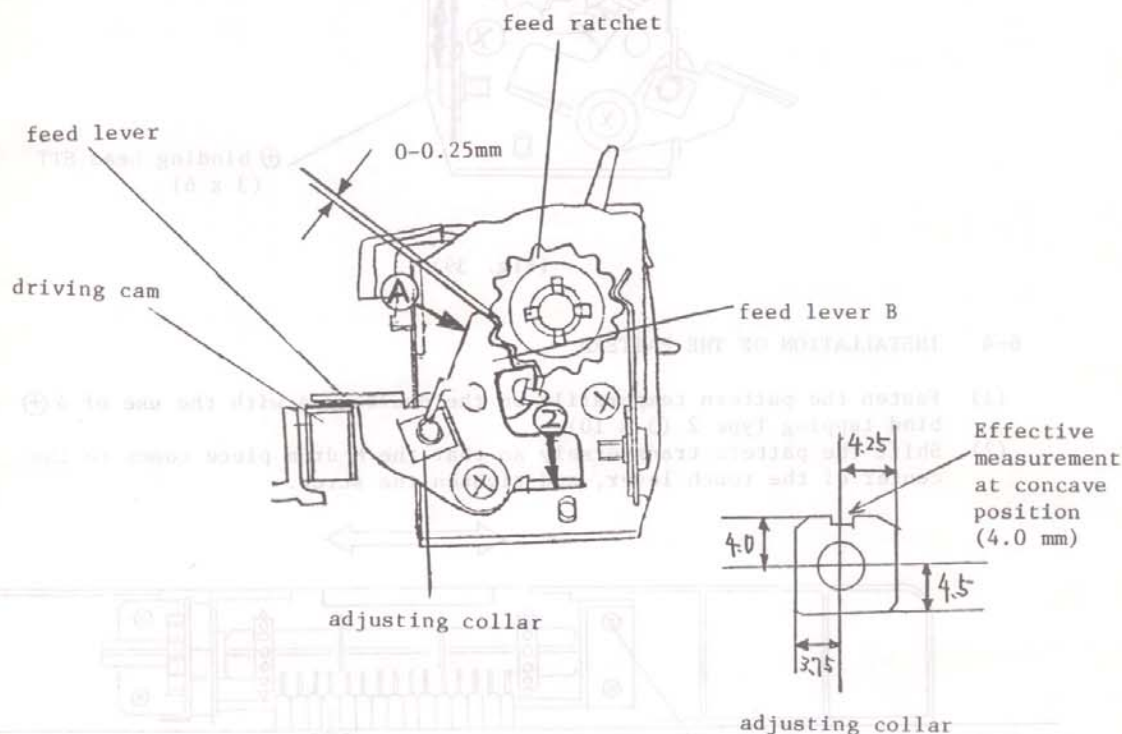

(Fig. 41)

6-6 INSTALLATION OF FEED DIAL AND ROW COUNTER

- (1) Fix the feed dial on the pattern shaft.
(note) If the feed dial is placed in a wrong direction, the pattern panel cannot be installed.
- (2) Install the RC lever to the row counter in such way that the RC lever comes beneath the feed lever and is fastened with a screw.

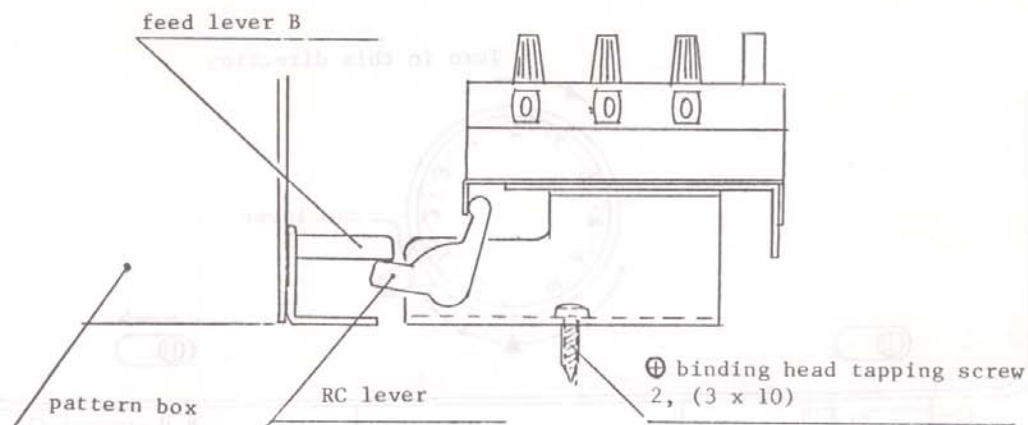

(Fig. 42)

[7] DISASSEMBLY, ADJUSTMENT AND INSTALLATION OF CARRIAGE

7-1 DISASSEMBLY OF CARRIAGE (to the removal of the carriage cover)

- (1) Turn the stitch dial to the end counterclockwise and pull it off when dial comes to stop (between 0 and 10).

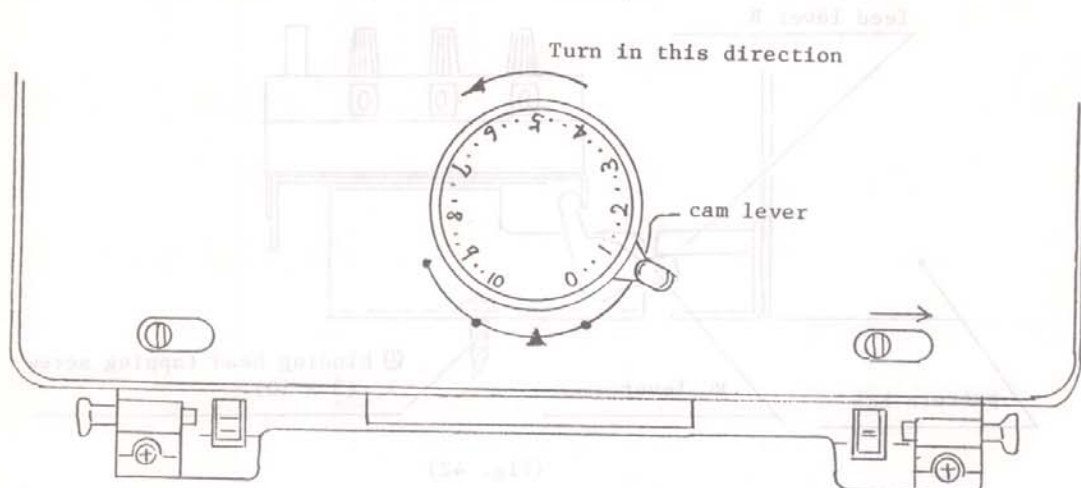

(Fig. 83)

- (2) Remove two bind small screws (3 x 4.5) which are on the back of the carriage cover.
- (3) Remove two bind TP type 2 (3 x 10) which are inside of the right and left arm stopper springs with the carriage reversed.

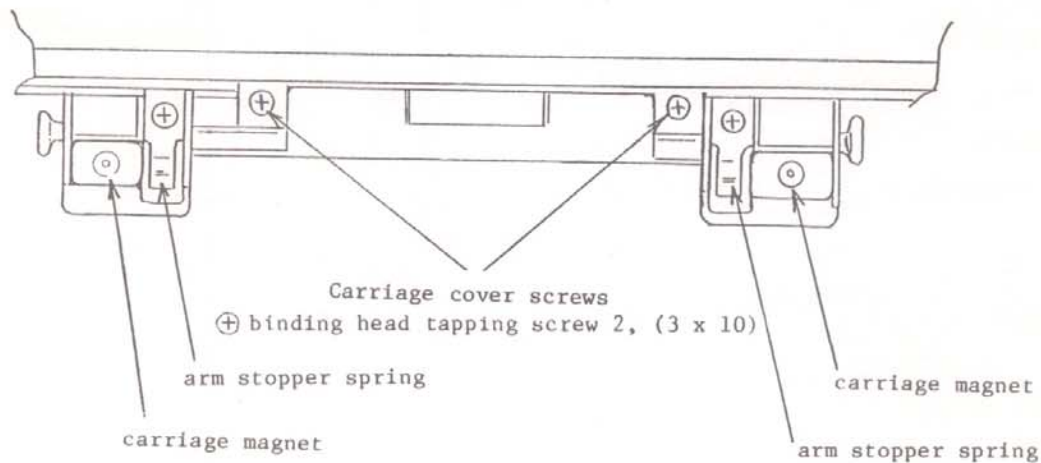

(Fig. 84)

- (4) Setting the cam lever to the knit-in position, pushing the dial spring forwardly as lifting up the cam lever with a forefinger; pull out the cam lever from the dial axis.

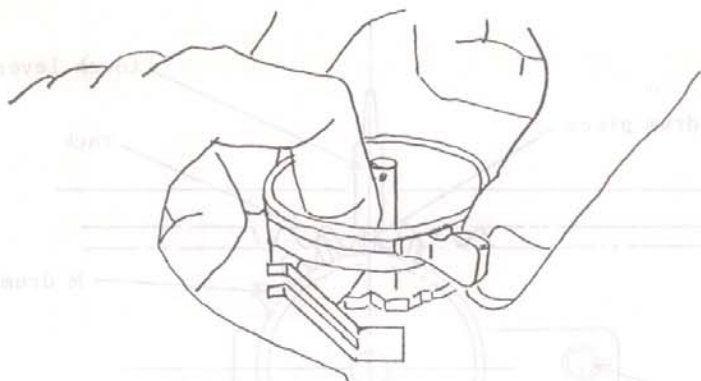

(Fig. 85)

7-2 ADJUSTMENT OF THE DRUM

- (1) Set the cam lever to the stockinet position. (to make it easy to see at the time of drum adjustment.)
- (2) Move the carriage and stop it when M drum piece comes to the center position of the touch lever.
- (3) Loosen 2 conical washer STT(3 x 8) which fasten the M drum base.
- (4) Adjust by moving the drum base right and left and back and forth so that the groove of the needlebed and the center of S drum piece (which has to be lowered) come on the same straight line.
Also ensure that M drum piece is at the center of the touch lever; and the groove of the needlebed, S drum piece, M drum piece, and the touch lever come on the same straight line.
- (5) The gap between M drum and the rack shall be around 0.2mm when measured circumferentially.

(note) When the tip of M drum piece and the center of the touch lever are not meeting correctly after the adjustment, adjust the right and left of the pattern assembly.

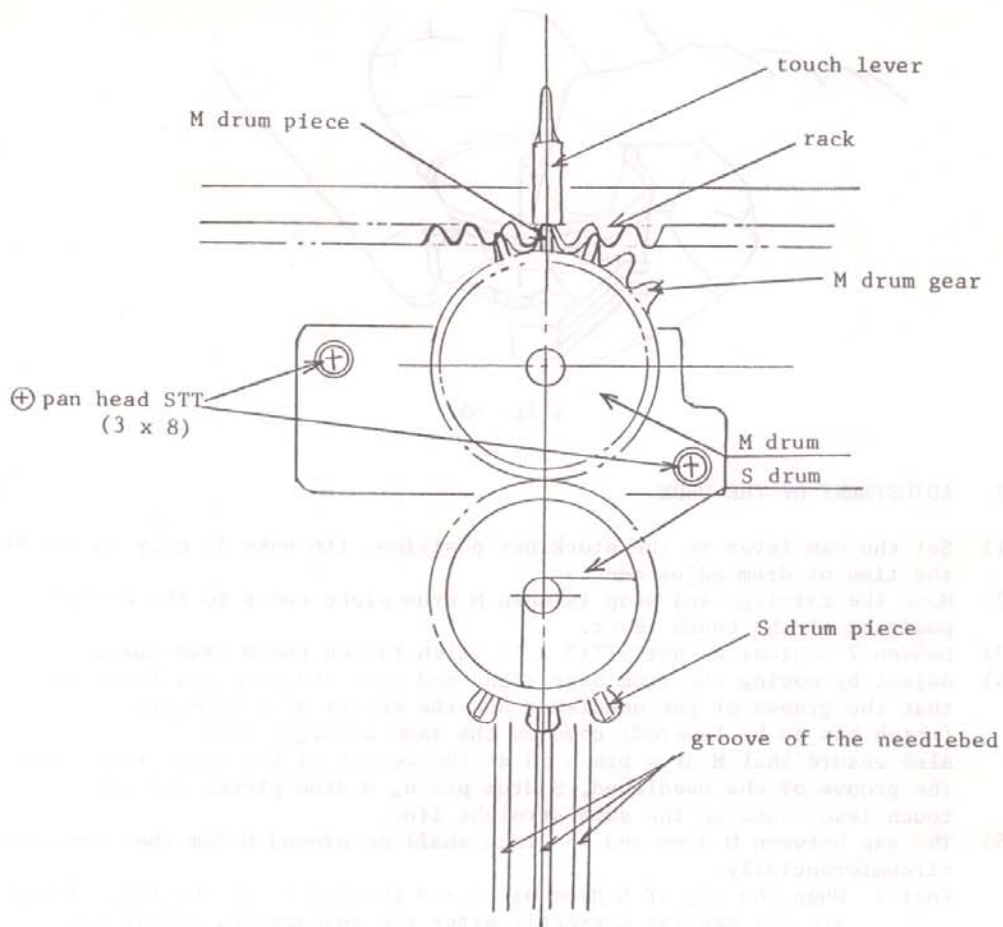

(Fig. 86)

7-3 ADJUSTMENT OF CLEAR WIRE

Since the position of the drum is slightly changed by the adjustment of the drum, it is necessary to adjust the length of the clear-wire which is to erase the memory of the drum.

- (1) Extend or contract the bent part of the clear-cam using pliers or radio pincers so that there is made approx. 0 - 1.0mm of clearance between clear-cam and clear-bar when A and B of the clear-cam come to touch together as the carriage is moved to the center of the needled as in the below figure and the clear-cam being operated by the clear-bar.

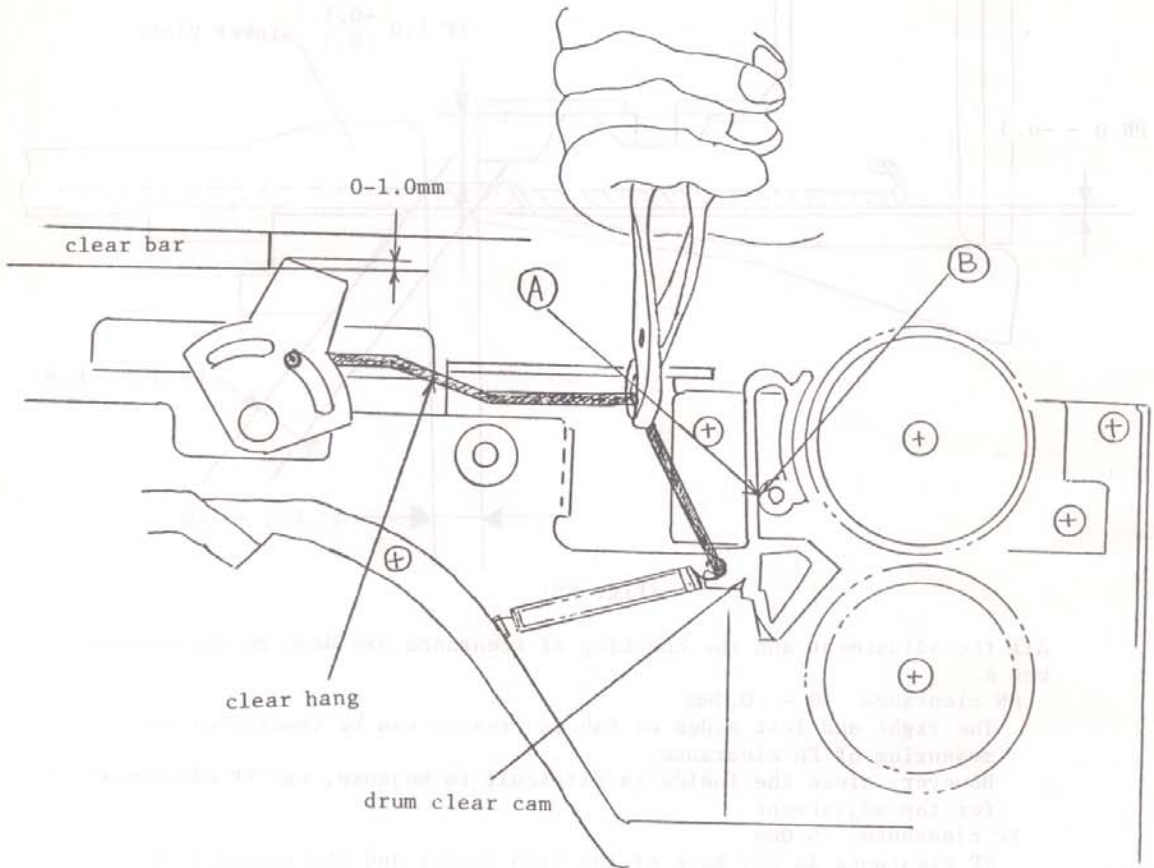

(Fig. 87)

[8] SIZES OF EACH PART & ADJUSTMENT OF ARM

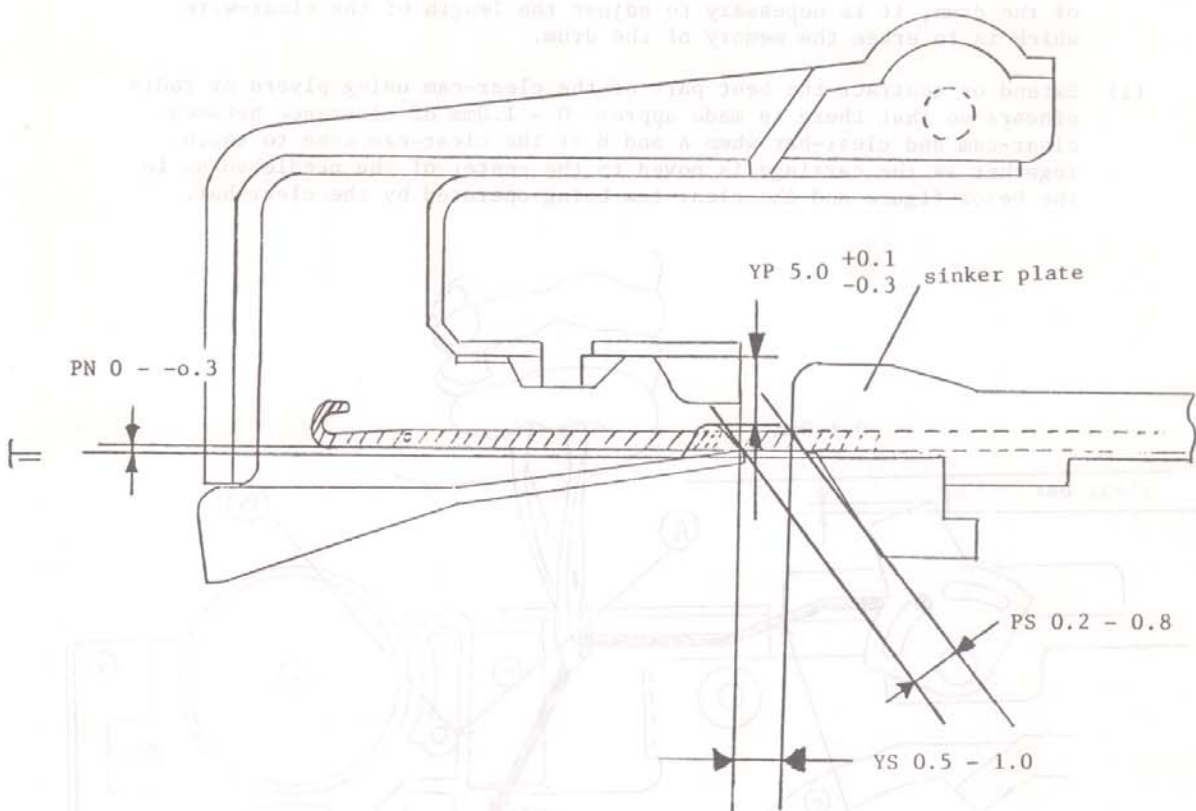

(Fig. 88)

All the adjustment and the checking of clearance are done on the needle-bed A.

PN clearance 0 - -0.3mm

The right and left sides of fabric presser can be checked at the measuring of PN clearance.

However, since the inside is difficult to measure, use YP clearance for the adjustment

YP clearance 5.0mm

YP clearance is for back of the Yarn Feeder and the convex part of fabric presser and the checking of the clearance shall be done by inserting screwdriver (thinner part).

PS clearance 0.2 - 0.8mm

Interference between fabric gear and the sinker plate occurs at the lowest clearance, 0.2mm.

Stitches get loosened because of the inadequate pressure at the cast-on (second time ↔) at the highest clearance, 0.8mm.

[9] HOW TO FIX UP OTHER INADEQUATE PLACES

condition	cause	fixing method
T slider thread A, B drops off from T base pulley.	<ol style="list-style-type: none"> 1. Because of the "twist" of T slider thread A & B, it drops off from T base pulley. 2. T base pulley runs idle. 3. Both of two T base pulleys are rotating. 4. Difference in level between T post A and T post B. 	<p>Remove T slider set R and L from T post and straighten up the "twist" of T slider thread A & B.</p> <p>Lubricate T base shift A & B.</p> <p>Exchange with a new part.</p> <p>Adjust the difference in level.</p>
Split thread occurs at the slip stitch and tuck stitch with using medium yarn at the stitch dial ⑨.	<ol style="list-style-type: none"> 1. Holding pressure to the knitted part is too weak. 2. The stitch dial is not adequate. 	<p>"simple rake" and rib weight are used.</p> <p>Adjust the stitch dial to the appropriate one.</p>
Stitches get loosened at the stockinet stitching with medium yarn at the stitch dial ⑩.	<ol style="list-style-type: none"> 1. Holding pressure to the knitted part is too weak. 2. Stitch dial has become impossible 	<p>Use "weight set" and rib weight.</p> <p>Change to appropriate knitted part method. (Knit as pulling the knitted part downwardly.)</p>
Gaps exist on the whole of the arm.	<ol style="list-style-type: none"> 1. A Gap exist between the arm stopper and the arm holder. 	<p>Adjust the spot indicated by an arrow of the arm stopper by bending there to minimize the gap of the whole arm.</p>

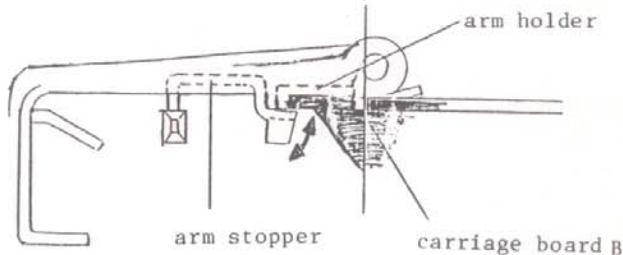

CAUSES FOR INADEQUATE STORAGE [I]

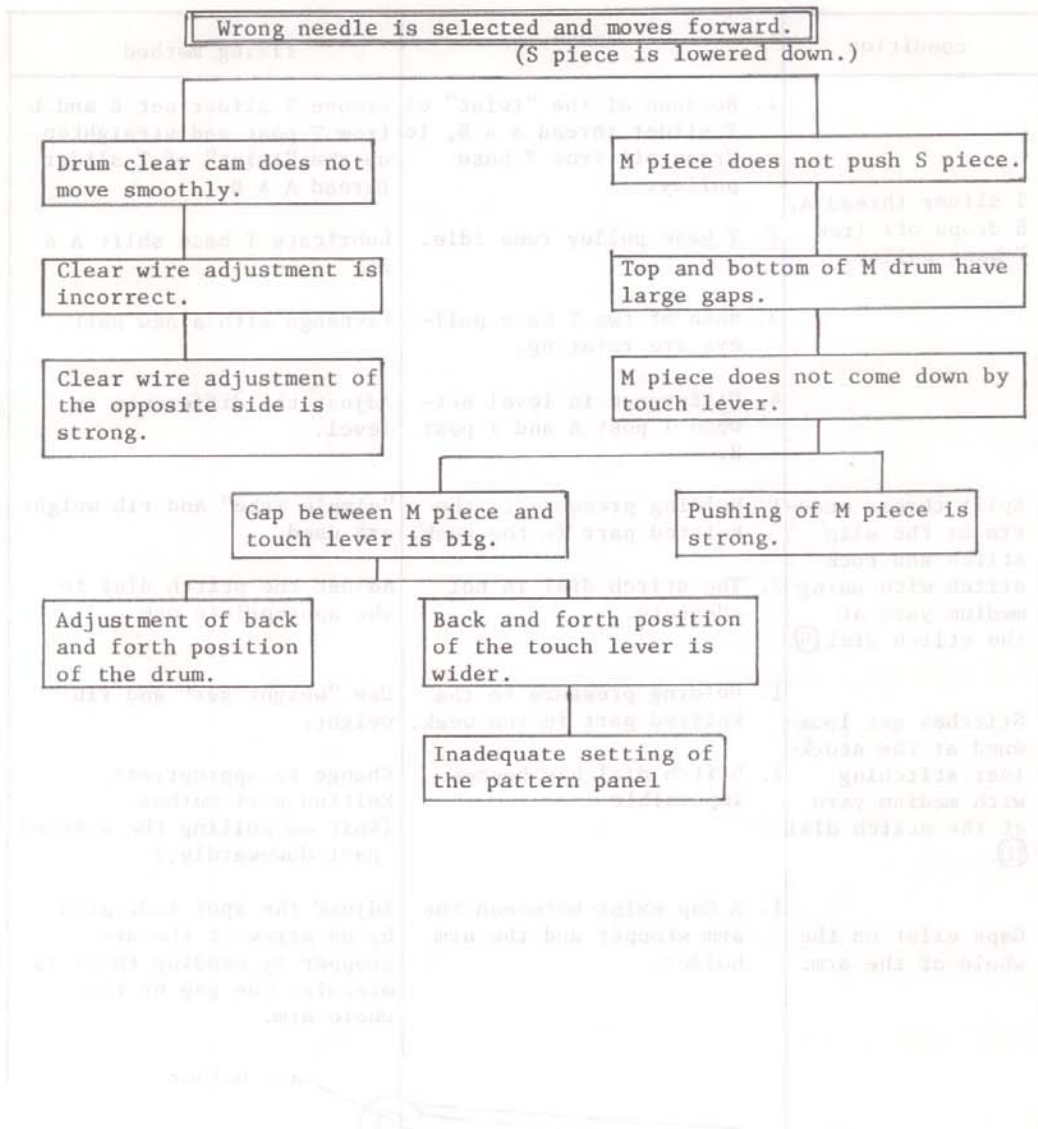

CAUSES FOR INADEQUATE STORAGE [II]

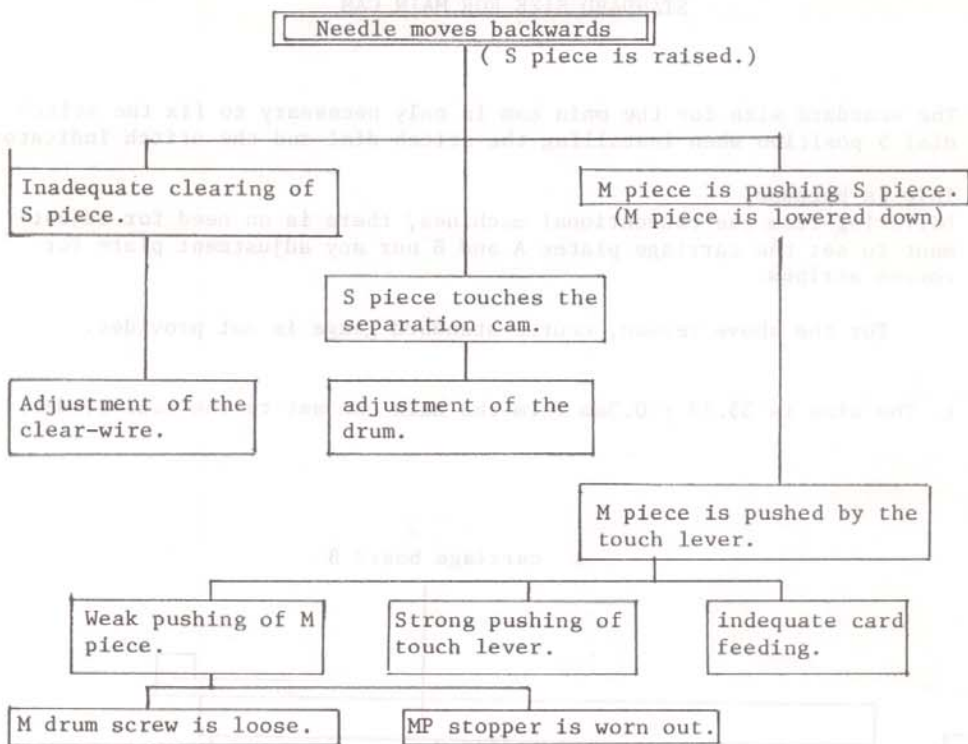

STANDARD SIZE FOR MAIN CAM

The standard size for the main cam is only necessary to fix the stitch dial 5 position when installing the stitch dial and the stitch indicator

This is because;

Differing from the conventional machines, there is no need for adjustment to set the carriage plates A and B nor any adjustment plate for course stripes.

For the above reason, course standard gauge is not provided.

1. The size is $33.13 \pm 0.3\text{mm}$ from the main cam set to the rear slider.

